

SERVICE INFORMATION DIRECTIVE

Compliance Will Enhance Safety, Maintenance or Economy Of Operation

SID97-3E

Technical Portions
 FAA APPROVED
 SUPERSEDES M73-22, M89-10,
 M92-17, SID98-10A, SID97-3,
 SID97-3A, SID97-3B, SID97-3C
 and SID97-3D,

SUBJECT: PROCEDURES AND SPECIFICATIONS FOR ADJUSTMENT OF TELEDYNE CONTINENTAL MOTORS (TCM) CONTINUOUS FLOW FUEL INJECTION SYSTEMS.

PURPOSE: Provide procedures and specifications for the adjustment of Teledyne Continental Motors (TCM) fuel injection systems.

COMPLIANCE: At Engine Installation, 100 hour/Annual Inspection, fuel system component replacement or as required if operation is not within specifications.

MODELS AFFECTED: All TCM continuous flow fuel injected engine models except IO-240-B w/ Bypass Fuel System; L/TSIO-360-RB; TSIO-520-L, LB, WB; GTSIO-520-F, K, N and GIO-550-A Engine Models.

WARNING

THE PROCEDURES AND VALUES PROVIDED IN THIS SERVICE BULLETIN APPLY TO TCM FUEL INJECTED ENGINES THAT HAVE NOT BEEN MODIFIED FROM THEIR ORIGINAL TYPE DESIGN. REFER TO SUPPLEMENTAL TYPE CERTIFICATE (STC) HOLDER INFORMATION AND INSTRUCTIONS FOR AIRCRAFT AND ENGINES THAT HAVE BEEN MODIFIED FROM THEIR ORIGINAL TYPE DESIGN.

GENERAL INFORMATION

Fuel injection system components manufactured by TCM are adjusted and calibrated to meet engineering specifications. This insures operation within those specifications throughout the full range of operation. Fuel injection system components installed on factory new and rebuilt engines are further adjusted to meet design specifications during operation in the production engine test facility. These tests and adjustments are carried out in an environment of controlled fuel supply pressures and calibrated test equipment.

When engines are installed in aircraft, they are subjected to a different induction system, fuel supply system and operating environment. These

differences require checking and adjusting the fuel injection system to meet operational specifications before flight.

Aircraft and engines that have been modified from their original type design must have the fuel injection system maintained in accordance with the Supplemental Type Certificate Holder's FAA approved instructions.

Operational verification of the engine fuel system is required any time one of the following circumstances occurs: (1) at engine installation, (2) during 100 hour and annual inspections, (3) whenever a fuel system component is replaced or adjusted, (4) when changes occur in the operating environment.

CAUTION: Engine performance, service life and reliability will be compromised if the engine's fuel injection system is neglected.

The following adjustment procedures are presented in a sequential format that must be followed to insure proper fuel system adjustment. Reference the applicable Aircraft Maintenance Manual for detailed fuel system adjustment and maintenance procedures.

ISSUED			REVISED			 Teledyne Continental Motors, Inc. <small>A Teledyne Technologies Company</small> P.O. Box 90 Mobile Alabama • 251-438-3411	PAGE NO	REVISION
MO	DAY	YEAR	MO	DAY	YEAR		1 of 38 SID97-3	E
03	24	1997	06	17	2008			

Any fuel system that cannot be adjusted to meet the specified values will require repair or replacement of the affected components prior to further engine operation.

The adjustment procedures provided in this SID also apply to engine fuel systems equipped with TCM Position Tuned Fuel Nozzles. Refer to Form X306474, Position Tuned Fuel Nozzle Installation and Maintenance Manual for more detailed information and installation instructions.

CAUTION: Refer to the torque specifications, Table 1, page 10 for specified values when torquing hose end fittings.

A. ADJUSTMENT TOOLS AND EQUIPMENT REQUIRED

A complete set of tools and test equipment is essential for correct setup of TCM fuel injection systems. Various combinations of these tools and equipment will be used, depending on the engine model. A proper inventory of tools and equipment for fuel system adjustment will include the following:

1. TCM recommends the Model 20 ATM-C Porta Test Unit P/N 630045-20 ATM-C or equivalent to insure the fuel injection system meets all pressure and flow specifications. You may acquire a Model 20 ATM-C Porta Test Unit by contacting the following company:

AERO TEST, Inc.
29300 Goddard Road
Romulus, Michigan 48174
(734) 946-7777

An alternative procedure would be to use calibrated gauges.

1. One (1) calibrated 0-60 PSI gauge, graduated in 1 PSI increments. This gauge will be used for unmetereed pressure measurement.
2. One (1) calibrated 0-30 PSI gauge, graduated in .2 PSI (maximum) increments. This gauge will be used for metered pressure measurements and verification of aircraft fuel flow gauge indications on normally aspirated engines only.
3. One (1) calibrated differential gauge, 0-30 PSID maximum, graduated in .2 PSI

(maximum) increments. This gauge will be used for metered pressure measurements and verification of aircraft fuel flow gauge on turbocharged engines only.

NOTE: Pressure gauges must be accurate within ± 1 %. Pressure gauges must be checked for accuracy and, if necessary, calibrated at least once each calendar year. Calibrated pressure gauges may be purchased from various suppliers such as:

Davis Instruments
4701 Mount Hope Drive
Baltimore, MD 21215
Phone: 410-358-3900 or
1-800-368-2516

4. Two (2) P/N MS51523-B4 swivel tee. These fittings will be used to tee into fuel lines for unmetereed and metered pressure reference.
5. Hoses of appropriate diameters and sufficient lengths to allow personnel and equipment to be located away from propeller arc and blast area.
6. Common hand tools including: 7/8", 11/16", 9/16", 1/2", 3/8", 7/16", 11/32", and 5/16" wrenches. A 1/4" drive ratchet and sockets, universal swivel, extension, and a 5/32" allen wrench common screw driver, a calibrated torque wrench, an oil can, mirror and flashlight. Safety equipment including hearing and eye protection must be used.
7. Tachometer verification instrument - various types are available. Verify aircraft tachometer accuracy prior to fuel system adjustment.

B. PRE-SETUP PROCEDURES

1. During engine installation, or if any fuel system component has been replaced, flush the aircraft fuel system by first removing the engine-driven fuel pump inlet hose and terminating the end into a large, clean container. Operate the aircraft boost pump and allow a minimum of one gallon of fuel to flow through the system. Take necessary precautions to prevent a fire hazard. If contamination is present, locate and correct the source, and repeat this step before proceeding.

ISSUED			REVISED			 Teledyne Continental Motors, Inc. <small>A Teledyne Technologies Company</small> P.O. Box 90 Mobile Alabama • 251-438-3411	PAGE NO	REVISION
MO	DAY	YEAR	MO	DAY	YEAR		2 of 38 SID97-3	E
03	24	1997	06	17	2008			

2. For all IO-240-B engines the following procedure must be used for fuel system flush whenever any fuel system component has been replaced:

- (a) Utilizing the airframe boost pump, flush a minimum of 1 quart of fuel from the fuel pump inlet hose into a clean, dry container. Inspect the flushed fuel. If free from contamination connect to the engine driven fuel pump using the appropriate maintenance instructions. If contamination issue before proceeding further.
- (b) Using the airframe boost pump, flush a minimum of 1 quart of fuel through the engine driven fuel pump into a clean, dry container while working the mixture control through it's full range of operation. Inspect the flushed fuel. If free from contamination, connect to the throttle and control unit using the appropriate maintenance instructions. If contamination is found, correct the issue before proceeding further.
- (c) Using the airframe boost pump, flush a minimum of 1 quart of fuel through the throttle and control unit into a clean, dry container while working the throttle control through it's full range of operation. Inspect the flushed fuel. If free from contamination connect to the manifold valve using the appropriate maintenance instructions. If contamination is found, correct the issue before proceeding further.
- (d) Using the airframe boost pump, flush a minimum of 1 quart of fuel through the fuel transducer hose into a clean dry container. Inspect the flushed fuel. If free from contamination, install the fuel transducer in accordance with the Diamond maintenance instructions. If contamination is found, correct the issue before proceeding further.
- (e) Using the airframe boost pump, flush the 4 fuel injector lines into 4 appropriate, clean, dry containers. If the flushed fuel is free from contamination, connect to the fuel injectors using the appropriate maintenance instructions. If contamination is found, correct the issue before proceeding further.

3. Before making any checks or adjustments, verify the accuracy of the aircraft tachometer, manifold pressure gauge and fuel flow gauge. Any gauge found to be inaccurate must be repaired or replaced before adjusting the fuel system.

WARNING

USE OF INACCURATE GAUGES WILL RESULT IN INCORRECT ADJUSTMENT OF THE ENGINE FUEL SYSTEM, POSSIBLE CYLINDER WEAR DUE TO LEAN OPERATION, PRE-IGNITION, DETONATION, LOSS OF POWER AND SEVERE ENGINE DAMAGE.

- 3. Remove the engine cowling in accordance with the aircraft manufacturer's instructions.
- 4. Insure that all fuel system components are of the correct part number and are installed properly. Correct any discrepancies noted.
- 5. Remove, inspect, clean and reinstall the aircraft and engine fuel screens in accordance with the aircraft manufacturer's instructions.
- 6. Inspect the aircraft induction air filter and alternate air system for condition, operation and cleanliness. Repair or replace any component that is not airworthy in accordance with the aircraft manufacturer's instructions.
- 7. Inspect the aircraft vapor return system for proper operation in accordance with the aircraft manufacturer's instructions. Correct any discrepancies noted.
- 8. Insure the fuel manifold valve vent and fuel pump drain lines are properly installed, open and free of obstruction. Correct any discrepancies noted.
- 9. Inspect all engine control rod ends for wear, freedom of movement, proper installation and security in accordance with the aircraft manufacturer's instructions. Correct any discrepancies noted.
- 10. Inspect the throttle and control assembly link rods (where used) for correct installation, security and wear at the attach points. Correct any discrepancies noted.

ISSUED			REVISED			 Teledyne Continental Motors, Inc. <small>A Teledyne Technologies Company</small> P.O. Box 90 Mobile Alabama • 251-438-3411	PAGE NO	REVISION
MO	DAY	YEAR	MO	DAY	YEAR		3 of 38 SID97-3	E
03	24	1997	06	17	2008			

11. Insure all engine controls operate freely throughout their full range of travel and are properly adjusted in accordance with the aircraft manufacturer's instructions.
12. Lubricate all control rod ends and fuel system components in accordance with the latest revision of TCM Service Bulletin SB95-2 and the Aircraft Maintenance Manual.

WARNING

FAILURE TO CORRECTLY INSTALL AND MAINTAIN ENGINE CONTROLS CAN RESULT IN LOSS OF SYSTEM CONTROL AND SUBSEQUENT LOSS OF ENGINE POWER.

13. Locate the IDLE speed stop screw on the throttlebody and turn it counter-clockwise two complete turns. See Figures 6, through 9. During fuel system adjustment, IDLE RPM will be controlled manually using the cockpit throttle control.
14. Inspect the exhaust and induction systems for proper installation, security and leaks. Correct any discrepancies noted.
15. Inspect all lines, hoses and wire bundles for chafing, loose connections, leaks and stains. Correct any discrepancies noted.

Turbocharged engine models incorporating a fuel pressure regulator must have the regulator deactivated during initial fuel system adjustment. To deactivate the fuel pressure regulator, loosen and remove the fuel line or hose from the "center" port fitting at the pressure regulator. Refer to Figure 10. Install and torque, to the specified value, a cap on the "center" port fitting. Install and torque, to the value specified, a plug onto the removed line. Pressure test these areas for fuel leaks prior to proceeding with the fuel system adjustments.

C. SETUP PROCEDURES

WARNING

DURING REMOVAL AND INSTALLATION OF FUEL LINES AND HOSES, FAILURE TO PROPERLY SUPPORT COMPONENT FITTINGS

CAN RESULT IN FITTING AND/OR COMPONENT DAMAGE AND LOSS OF SYSTEM PRESSURE. REFERENCE THE LATEST REVISION OF TCM SERVICE BULLETIN SIL95-5.

NOTE: Adjustments to any component of the fuel injection system can affect other system settings. Always verify the performance of the entire fuel injection system whenever any fuel injection system component is adjusted.

1. Loosen and remove the unmetered fuel supply hose from the fuel pump outlet fitting, the fuel control unit inlet fitting, or the throttle body/metering unit inlet Tee whichever is most accessible. Some engine models have a fuel pressure connection fitting in the fuel control inlet screen that may be utilized for unmetered pressure gauge attachment.
2. For engine models with integral throttle body/metering units, remove and set aside the 639494 cap fitting from the inlet Tee. This cap will be reinstalled after setup is complete.
3. Install and torque the MS51523-B4 swivel tee directly to the fuel pump outlet fitting or to the fuel control inlet fitting as applicable.

NOTE: Some installations may require combinations of different fittings and hoses to facilitate installation of unmetered and metered test equipment connections.

3. Attach the unmetered fuel supply hose to the straight end of the tee connector and torque.
4. Connect the Unmetered test hose from the *Porta Test Unit* to the tee fitting and torque. If using the alternative procedure, connect the 0-60 PSI gauge to the swivel tee using a length of hose which will provide proper clearance from the engine cowling and propeller arc. Torque all connections.
5. Loosen and remove the metered fuel supply hose from the manifold valve inlet fitting.
6. Install and torque the second MS51523-B4 swivel tee directly to the fuel manifold valve inlet fitting.

ISSUED			REVISED			 Teledyne Continental Motors, Inc. <small>A Teledyne Technologies Company</small> P.O. Box 90 Mobile Alabama • 251-438-3411	PAGE NO	REVISION
MO	DAY	YEAR	MO	DAY	YEAR		4 of 38 SID97-3	E
03	24	1997	06	17	2008			

7. Attach the metered fuel supply hose to the straight end of the tee connector and torque.
8. Connect the metered pressure test hose from the *Porta Test Unit* to this second tee connector and torque. If using the alternative procedure, connect the 0-30 PSI gauge to the swivel tee using a hose long enough to provide proper clearance from the engine cowling and propeller arc. Torque all connections.
9. On turbocharged engines, connect the Porta-Test Manifold Pressure and Upper Deck Pressure hose to the engine following the instructions provided with the Porta Test Unit. If using the alternative procedure, connect the 0 - 30 PSID differential gauge pressure fitting to the metered pressure swivel tee using a hose of sufficient length to provide clearance from the aircraft and propeller arc. Connect an equal length of hose to the "suction" side of the gauge and connect the other end to a location to reference turbocharger compressor discharge (upper deck) pressure. See Figure 12. Torque all connections.
10. Position the throttle control in the FULL OPEN position and the mixture control to FULL RICH. Operate the aircraft boost pump in accordance with the aircraft manufacturer's instructions. Following the instructions provided with the Porta Test Unit, bleed all air from the test unit and hoses. If using the alternative calibrated test gauges, loosen the test connections at each gauge to bleed the lines of any air. Hold the gauge at or slightly above the height of the fuel system component during the bleeding operation. Operate the boost pump only long enough to allow purging of air from the installed test equipment. Verify that all fuel lines, hoses and fittings are secured and torqued and that no fuel leaks exist before proceeding. Insure test hoses have been routed clear of the exhaust system and are supported their entire length to avoid inaccurate gauge readings.

WARNING

MAKE CERTAIN ALL FUEL HAS DRAINED FROM THE INDUCTION SYSTEM PRIOR TO

ISSUED			REVISED			 Teledyne Continental Motors, Inc. <small>A Teledyne Technologies Company</small> P.O. Box 90 Mobile Alabama • 251-438-3411	PAGE NO	REVISION
MO	DAY	YEAR	MO	DAY	YEAR		5 of 38 SID97-3	E
03	24	1997	06	17	2008			

ATTEMPTING ENGINE START. FAILURE TO DO SO COULD CAUSE HYDRAULIC LOCK AND SUBSEQUENT ENGINE FAILURE.

11. Install the engine cowling or cooling shroud during ground operation.
12. Refer to TABLE 3, beginning on page 11, for specific data applicable to your engine. Record the applicable IDLE and FULL POWER adjustment points: RPM, fuel pressure, fuel flows, manifold pressure and fuel/air mixture rise provided in this Service Bulletin and Aircraft Maintenance Manual on the operational test form included at the end of this service bulletin. The Operational Test Form may be reproduced for use in recording adjustments and test indications.

NOTE: To insure optimum cooling during FULL POWER operations, the FULL POWER fuel flow should be set to the maximum specification limit.

WARNING

BEFORE STARTING THE ENGINE INSURE THAT THE AIRCRAFT WHEELS ARE CHOCKED AND BRAKES ARE SET.

13. Prepare the aircraft for ground run and start the engine in accordance with the aircraft manufacturer's instructions. Advance the throttle to 1500 to 1800 RPM. While monitoring all engine gauges, operate the engine at this speed until the engine temperatures and pressures have stabilized in the operational range. Use the operational test form to record the gauge indications.

NOTE: Test gauge readings must be taken with the gauges held at the same height above the ground as the fuel system component it is attached to.

14. With the mixture control in the FULL RICH position, reduce the throttle to the specified IDLE RPM. Record the unmetered pressure indicated on the gauge. Slowly move the mixture control toward the IDLE CUT-OFF position and record the maximum RPM rise. Return the mixture control to FULL RICH.

15. Monitoring all engine gauges, slowly advance the throttle control to full rated power for the engine and allow the engine to stabilize for 15 seconds. Record all engine and test gauge indications. **DO NOT ALLOW ENGINE TEMPERATURES TO EXCEED 420°F CHT AND 210°F OIL TEMP.** Retard throttle control to 800 to 1000 RPM.

NOTE: L/TSIO-360 and TSIO-520 model engines with a fixed (ground adjustable) exhaust bypass, verify that the wastegate is adjusted in accordance with the aircraft manufacturer's instructions. Failure to do so can result in an improperly adjusted fuel system and possible engine damage.

CAUTION: After FULL POWER operation - turbocharged engines must be operated at 800 to 1000 RPM for a minimum of five (5) minutes to allow engine temperatures to stabilize prior to engine shutdown.

16. Compare the recorded IDLE fuel pressure, IDLE RPM fuel/air mixture rise and full power RPM, manifold pressure (as applicable), unmetered fuel pressure, metered fuel pressure and fuel flow indications with the specified values. If all recorded values are within specifications, proceed to paragraph 24.

NOTE: Turbocharged engines equipped with fuel pressure regulators should indicate a full power metered pressure and fuel flow five (5) percent higher than specified. This is required to insure adequate part-throttle fuel flow.

17. If any of the recorded readings are not within specifications, the fuel system must be completely adjusted. **ALL READINGS MUST BE TAKEN WITH MIXTURE CONTROL IN THE FULL RICH POSITION.** Install the engine cowling or cooling shroud during all ground operation.

NOTE: Engine driven fuel pump output pressures vary with engine RPM. During ground operation FULL POWER RPM may not be obtained. Use the Fuel Flow Compensation Table 2 on page 10 to correct the specified metered pressures if FULL POWER RPM cannot be

achieved. On turbocharged engines insure that the manifold pressure is adjusted in accordance with the aircraft manufacturer's instructions. Engine driven fuel pumps installed on turbocharged engines are referenced to turbocharger compressor discharge pressure (upper deck pressure) to achieve FULL POWER engine driven fuel pump pressure.

WARNING

MAKE ALL ADJUSTMENTS WITH THE ENGINE STOPPED AND THE IGNITION AND MASTER SWITCHES IN THE OFF POSITION.

18. To adjust the IDLE RPM unmetered pump pressure, loosen the lock nut on the low pressure relief valve. See Figures 1 through 5. Turning the adjustment clockwise (CW) will increase pressure and counterclockwise (CCW) will decrease pressure. Operate the engine at 1500-1800 RPM for 15 seconds after each adjustment, then retard the throttle to the specified IDLE RPM. Repeat this step until pressure is within specified limits.

CAUTION: All adjustments on the IO-240-B engine must be made with the boost pump on.

NOTE: Maximum part throttle full rich fuel flow will be achieved by setting the idle rpm (low) unmetered fuel pump pressure to the minimum value specified. With the idle rpm fuel/air mixture properly adjusted (step 19) the fuel control metering plate orifices are indexed to the maximum open position.

19. With engine operating at the specified IDLE RPM and unmetered fuel pressure, slowly move the mixture control from the FULL RICH position toward IDLE CUT-OFF to check fuel/air mixture. A rise of 25 to 50 RPM should be obtained. (For the IO-240-B equipped with the standard fuel system mixture rise must be 50-75 RPM) An RPM change greater than 50 (75 for the IO-240-B equipped with the standard fuel system) indicates the mixture is too rich and a change that is less than 25 (50 for the IO-240-B equipped with the standard fuel system) indicates the mixture is too lean. Adjust

ISSUED			REVISED			 Teledyne Continental Motors, Inc. <small>A Teledyne Technologies Company</small> P.O. Box 90 Mobile Alabama • 251-438-3411	PAGE NO	REVISION
MO	DAY	YEAR	MO	DAY	YEAR		6 of 38 SID97-3	E
03	24	1997	06	17	2008			

mixture conditions that are too rich or too lean as follows:

- a) Identify the type of throttle and control assembly that is to be adjusted. See Figures 6, 8 and 9.
 - b) Perform an IDLE fuel/air mixture check and observe RPM rise. If the RPM rise is not within specifications, advance the throttle control to 1500 - 1800 RPM for 15 seconds after each adjustment to clear the engine. Retard the throttle control to IDLE RPM and repeat mixture check. Make the necessary adjustment. Repeat this procedure until the specified RPM rise is achieved.
 - c) Recheck IDLE RPM unmetered pump pressure. If pressure is not within limits, repeat Steps 18, 19, 19-a and 19-b before continuing.
20. On all naturally aspirated engines, adjust the FULL POWER metered fuel pressure to the specified value by turning the adjustable orifice screw clockwise to increase fuel pressure and counterclockwise to decrease fuel pressure. See Figures 1, 2 and 3.
21. On turbocharged engines, adjust the full power metered fuel pressure to the specified value as follows:

NOTE: On turbocharged engines equipped with a fuel pressure regulator, the full power metered fuel pressure and fuel flow must be adjusted to five (5) percent higher than the maximum specified limit.

- a. Loosen the aneroid adjustment screw lock nut. See Figures 4 and 5.
- b. Turn the aneroid adjustment screw counterclockwise to increase metered fuel pressure and clockwise to decrease metered fuel pressure.
- c. After final adjustment is accomplished, torque lock nut to 25-30 inch pounds. **DO NOT EXCEED LOCK NUT TORQUE LIMITS. OVER-TORQUING OF LOCK**

NUT WILL RESULT IN DAMAGE TO ANEROID HOUSING THREADS AND SUBSEQUENT LOSS OF ADJUSTMENT.

22. For engines equipped with a fuel pressure regulator, the full power metered fuel pressure and fuel flow must now be set to the specified limit by adjustment of the regulator as follows. See Figure 10. Reconnect the regulator and torque all connections to the specified value. Loosen the lock nut on the regulator adjustment. Turn the regulator adjusting screw clockwise to increase metered fuel pressure and fuel flow and counterclockwise to decrease metered fuel pressure and fuel flow. After final adjustment is completed, torque the lock nut to the specified value.
23. When full power metered fuel pressure has been adjusted to the specified values, recheck: (a) IDLE RPM, (b) unmetered fuel pressure, (c) fuel/air mixture. If any values are not within specified limits, repeat the adjustment procedures.
24. With the fuel system set to the specified metered fuel pressure, set the IDLE RPM to the aircraft manufacturer's specified value by turning the Idle Speed Stop screw clockwise to increase RPM or counterclockwise to decrease RPM. See Figures 6, 8 and 9.

D. POST SETUP PROCEDURES

1. Insure that the master switch, ignition switch and fuel selector are in the OFF position.
2. Remove the engine cowling or cooling shroud in accordance with the aircraft manufacturer's instructions. (a) remove all test gauges, fittings and hoses that were installed for fuel system setup, (b) reconnect all fuel hoses and cap fittings to their original locations, (c) support and torque all fittings to the specified value, see TABLE 1.
3. **ASSURE CAP ASSEMBLY 639494 IS CORRECTLY INSTALLED ON INLET TEE FITTING OF COMBINATION THROTTLE BODY/METERING UNITS. TORQUE TO**

ISSUED			REVISED			 Teledyne Continental Motors, Inc. <small>A Teledyne Technologies Company</small> P.O. Box 90 Mobile Alabama • 251-438-3411	PAGE NO	REVISION
MO	DAY	YEAR	MO	DAY	YEAR		7 of 38 SID97-3	E
03	24	1997	06	17	2008			

135-190 INCH POUNDS PER TABLE 1 SPECS. UNDER NO CIRCUMSTANCE ALLOW ANY CAP FITTING OTHER THAN 639494 TO BE INSTALLED DURING ENGINE OPERATION.

4. Perform a complete fuel system leak check in accordance with the aircraft manufacturer's instructions. Correct any discrepancies noted.
 - Turn aircraft master switch to ON position
 - Adjust mixture control to full rich
 - Adjust throttle control to 1/4 inch open
 - Activate the aircraft boost pump (ON)
 - Inspect entire fuel system for fuel leakage
 - Return mixture and throttle to idle/closed position
 - Turn aircraft boost pump OFF
 - Turn the aircraft master switch OFF
5. Install engine cowling in accordance with the aircraft manufacturer's instructions.
6. Perform a complete operational ground run-up and verify that all fuel system performance specifications are achieved.

**E. FLIGHT TEST:
Except naturally aspirated engines
with altitude compensating fuel
pump**

1. Refer to the aircraft manufacturer's or Supplemental Type Certificate (STC) holder's POH/AFM for specific operational information.
2. A flight test is required whenever an adjustment is made that may affect engine operational characteristics or performance.
3. If FULL POWER RPM was not obtained during fuel injection system setup and adjustment, a flight test is required to insure that the fuel injection system is performing within specified limits for the engine and aircraft.

4. Repeat the setup and adjustments as required until the fuel injection system is performing within the published specification for the aircraft and engine.

**F. FLIGHT TEST:
Naturally Aspirated engines with
altitude compensating fuel pumps
(AUTO LEAN)**

1. All naturally aspirated engines utilizing an altitude compensating fuel pump require a flight test at: (a) Initial installation, (b) Every 12 months (Scheduled to coincide with annual or 100 HR inspection), (c) each time adjustments are made due to a fuel system component replacement and (d) at any indication of improper auto-leaning feature operation.
2. Table 5 and Chart 1 provide fuel flow vs. pressure altitude specifications for the IO-240-B series engine with altitude compensating fuel pumps. Table 6 and Auto Leaning Chart 3 provide fuel flow vs. pressure altitude specifications for the IO-360-DB engine with altitude compensating fuel pump. Tables 7 & 8 and Auto Leaning Charts 4 & 5 provide fuel flow vs. pressure altitude specifications for the IO-360-ES engine with altitude compensating fuel pump. Tables 9 through 12 and Auto Leaning Charts 6 through 9 provide fuel flow vs. pressure altitude specifications for the IO-550- series engine with altitude compensating fuel pumps.
3. Insure the accuracy of aircraft fuel flow gauge and tachometer has been verified. These gauges must be accurate or the data recorded during flight test will not be valid.
4. Locate the correct table and auto leaning chart for the aircraft and engine. On the operational test form provided in this Service Information Directive, record all pressure altitudes and corresponding minimum and maximum fuel flows as specified.
5. In accordance with the aircraft manufacturer's instructions, perform a complete preflight inspection, engine start and ground runup.

ISSUED			REVISED			 Teledyne Continental Motors, Inc. <small>A Teledyne Technologies Company</small> P.O. Box 90 Mobile Alabama • 251-438-3411	PAGE NO	REVISION
MO	DAY	YEAR	MO	DAY	YEAR		8 of 38 SID97-3	E
03	24	1997	06	17	2008			

6. Set the aircraft altimeter to 29.92 inches Hg.
7. In accordance with the aircraft manufacturer's instructions, conduct a normal take-off.
8. Climb must be accomplished using full throttle, FULL RICH mixture and maximum rated full power RPM.
9. Using the aircraft fuel flow gauge and altimeter, record fuel flows at all pressure altitudes specified.
10. Compare the recorded fuel flows with the specified fuel flows for all pressure altitudes. If fuel flows are within the minimum and maximum limits at all altitudes, no adjustments are required.
11. If the fuel flows are not within specified limits at all pressure altitudes, the fuel injection system auto leaning schedule requires adjustment.

G. ADJUSTMENT PROCEDURES:

Fuel Pump Auto Leaning Schedule

NOTE: On IO-550-A and C model engines do not attempt to adjust the auto leaning schedule if the aircraft is at a field with a pressure altitude greater than 1000 feet.

On IO-550-B, D, E, F and L model engines, do not attempt to adjust the auto leaning schedule if the aircraft is at a field with a pressure altitude greater than 3000 feet.

Refer to Part C of this Service Information Directive for installation of the required test equipment.

1. If not previously accomplished, adjust the engine fuel injection system in accordance with Part C of this Service Information Directive using the appropriate table for the engine and aircraft.
2. Adjustments to the engine-driven fuel pump variable orifice (aneroid) will result in a change to the auto leaning schedule. One complete revolution of the aneroid adjustment will increase or decrease the auto leaning schedule approximately 1000 feet.

3. Refer to the charts on pages 19 to 25. The variable orifice (aneroid) adjustment will move you horizontally across the chart. The adjustable orifice will move you vertically.
4. Adjustments to the variable orifice (aneroid) will affect the FULL POWER unmetered fuel pressures (adjustable orifice), metered pressures and fuel flows. It is important to maintain the balance between these adjustments in order to achieve the specified fuel system parameters.

CAUTION: Exercise caution when adjustments to the aneroid are accomplished. The aneroid stem has an extra fine thread and over-torquing the lock nut will damage either the stem or housing threads.

NOTE...

It will be necessary to cut and remove the safety wire and manufacturer's seal from the variable orifice adjustment. Cut the safety wire as close to the variable orifice stem as possible. This will provide a pigtail for the fuel pump through bolts. It is not necessary to resafety the aneroid after adjustments have been completed.

5. By reviewing the data recorded on the operational test flight form, we can determine if the auto leaning schedule is above or below the specified limits at the various pressure altitudes.
6. Adjustment of the variable orifice (aneroid) clockwise will decrease the altitude (move horizontally to the left on the chart) while counterclockwise adjustments will increase the altitude (move horizontally to the right on the chart) at a given pressure altitude.
7. As an example, looking at chart number 5 (IO-550-B engine) at a pressure altitude of 4000 feet the recorded fuel flow was 140 PPH (point A). The fuel flow specified for this pressure altitude is 142 PPH to 152 PPH. The recorded fuel flow of 140 PPH would be correct if we were between 5000 feet and 7000 feet. To achieve the specified fuel flow versus pressure altitude we must adjust the variable orifice out. Adjustment of the variable orifice (aneroid) two complete revolutions will move point A two thousand feet to the right to 6000 feet.

ISSUED			REVISED			 Teledyne Continental Motors, Inc. <small>A Teledyne Technologies Company</small> P.O. Box 90 Mobile Alabama • 251-438-3411	PAGE NO	REVISION
MO	DAY	YEAR	MO	DAY	YEAR		9 of 38 SID97-3	E
03	24	1997	06	17	2008			

8. After making any adjustments to the variable orifice, torque the lock nut to 25-30 inch pounds.
9. Perform a complete ground run-up and verify that unmetered and metered pressures and fuel flows are within the limits specified in the appropriate table for the pressure altitude. If these parameters are not within the limits specified make adjustments in accordance with PART C to achieve the specified values.
10. Once the adjustments are completed, remove the test equipment in accordance with part D (Post Setup Procedures).
11. Perform a flight test in accordance with part F (Flight Test: Naturally Aspirated engines with Auto Lean).
12. Repeat these procedures until the engine's fuel injection system meets all published specifications.

NOTE...

The adjustable orifice tapered needle may be damaged if forced against its seat. The adjustment should move freely. Do not continue adjustments if rotational resistance increases suddenly.

TABLE 1
Torque Specifications for Hose End and Cap Fittings

BRASS or ALUMINUM END FITTINGS/CAPS		
Hose Size	Fitting Material	Torque (inch lbs.)
#2 (.31x24)	Hose end fitting Brass/Aluminum	50 – 80
#3 (.38x24)	Hose end fitting Brass/Aluminum	70 – 105
#4 (.4375x20)	Hose end fitting Brass/Aluminum	100 – 140
#5 (.500x20)	Hose end fitting Brass/Aluminum	130 – 180
#6 (.5625x18)	Hose end fitting Brass/Aluminum	150 – 195
#8 (.750x16)	Hose end fitting Brass/Aluminum	270 – 350
#10 (.875x14)	Hose end fitting Brass/Aluminum	360 – 430
#12 (1.063x12)	Hose end fitting Brass/Aluminum	460 – 550

STEEL HOSE END FITTINGS/CAPS		
Hose Size	Fitting Material	Torque (inch lbs.)
#2 (.31x24)	Steel End Fitting	75 – 120
#3 (.38x24)	Steel End Fitting	95 – 140
#4 (.4375x20)	Steel End Fitting	135 – 190
#5 (.500x20)	Steel End Fitting	170 – 240
#6 (.5625x18)	Steel End Fitting	215 – 280
#8 (.750x16)	Steel End Fitting	470 – 550
#10 (.875x14)	Steel End Fitting	620 – 745
#12 (1.063x12)	Steel End Fitting	855 – 1055

ISSUED			REVISED			 Teledyne Continental Motors, Inc. <small>A Teledyne Technologies Company</small> P.O. Box 90 Mobile Alabama • 251-438-3411	PAGE NO	REVISION
MO	DAY	YEAR	MO	DAY	YEAR		10 of 38 SID97-3	E
03	24	1997	06	17	2008			

Table 2.
Compensation Table For Static Ground Setup

Metered Pressure vs. RPM @ 70°F Fuel Temperature		
Static Engine RPM	Correction Factor	Corrected Metered Pressure (Metered Pressure x Correction Factor)
Rated RPM	1	
-20	.991	
-40	.982	
-60	.973	
-80	.964	
-100	.955	
-120	.946	

NOTE: All values are approximate. Variations may occur due to engine and installation specific influences.

Example: IO-520-BB, Maximum Rated RPM = 2700
Metered Fuel Pressure Limits = 14.9 - 17.2

If maximum static engine RPM = 2640, (-60 RPM) use Correction Factor .973
Metered Fuel Pressure Limits x Correction Factor = Corrected Metered Pressure Limits

14.9 x .973 = 14.5 (Minimum Metered Pressure Limit) @ 2640 RPM
17.2 x .973 = 16.7 (Maximum Metered Pressure Limit) @ 2640 RPM

ISSUED			REVISED			 Teledyne Continental Motors, Inc. <small>A Teledyne Technologies Company</small> P.O. Box 90 Mobile Alabama • 251-438-3411	PAGE NO	REVISION
MO	DAY	YEAR	MO	DAY	YEAR		11 of 38 SID97-3	E
03	24	1997	06	17	2008			

TABLE 3. Fuel System Adjustment Values

IDLE AND FULL POWER FUEL PRESSURES AND FLOWS					
ENGINE SEE NOTE 7	Prop. RPM & (MAP)	Unmetered Pump PSI (NOTE 3)	Metered Nozzle PSI (NOTE 4)	Fuel lbs/hr (NOTE 5)	Fuel gal/hr (NOTE6)
IO-240-A, B (a)(c)	1000	9.4 - 9.8	TABLE 4	-	-
IO-240-A, B (b) (c)	Full Throttle	See (b) and (c)	See (b) and (c)	-	-
<p>(a) For IO-240-A, B with standard fuel pump installed. Boost pump "ON", idle mixture rise to be 50-75.</p> <p>(b) For IO-240-B series with optional Altitude Compensating Pump and Standard Fuel Manifold Valve, see Chart 1 and Table 5 for instructions. See Note 2 page 18 of 38.</p> <p>(c) For IO-240-B engines, which are equipped with the Altitude Compensating Bypass Fuel System, see the latest revision of TCM bulletin SID07-3.</p>					
IO-346-A, B	600	7.0 - 7.5		-	-
	2700	19.0 - 21.0	12.5 - 14.0	78 - 85	13.3 - 14.5
IO-360-A, AB, C CB, D, DB(d), G, GB, H, HB, J, JB	600	7.0 - 9.0		-	-
	2800	24.0 - 27.0	15.8 - 18.2	100 - 106	17.0 - 18.1
IO-360-ES (d) SEE NOTE 2	600	7.0 - 9.0		-	-
	2800	23.0 - 26.0	14.3 - 16.5	100 - 107	17.0 - 18.1
IO-360-ES (CIRRUS) (d) SEE NOTE 2&6 Sea Level	600	7.0 - 9.0		-	-
	2700	21.0 - 24.0	13.8 - 15.5	96 - 102	16.4 - 17.4
IO-360-ES (CIRRUS) (d) SEE NOTE 2&6 1,500 Press Alt	600	7.0 - 9.0		-	-
	2700	19.0 - 22.0	13.3 - 14.6	94 - 98	16.0 - 16.6
(d) Engines with Altitude Compensating fuel pumps See Note 2 page 18 of 38.					
IO-360-K, KB	600	7.0 - 9.0		-	-
	2600	21.0 - 24.0	14.3 - 16.3	93.5 - 97.5	15.9 - 16.6
TSIO-360-A, AB	600	6.5 - 7.5		-	-
	2800 (32.0)	27.2 - 31.2	15.8 - 16.7	119 - 124	20.1 - 21.0
TSIO-360-B, BB	600	6.5 - 7.5		-	-
	2800 (32.0)	27.2 - 31.2	15.8 - 16.7	115 - 124	20.1 - 21.0
TSIO-360-C, CB	600	6.5 - 7.5		-	-
	2800 (37.0)	34.0 - 37.0	16.7 - 19.3	135 - 145	23.0 - 24.7

ISSUED			REVISED			 Teledyne Continental Motors, Inc. <small>A Teledyne Technologies Company</small> P.O. Box 90 Mobile Alabama • 251-438-3411	PAGE NO	REVISION
MO	DAY	YEAR	MO	DAY	YEAR		12 of 38 SID97-3	E
03	24	1997	06	17	2008			

TABLE 3. Fuel System Adjustment Values (cont'd)

IDLE AND FULL POWER FUEL PRESSURES AND FLOWS					
ENGINE SEE NOTE 7	Prop. RPM & (MAP)	Unmetered Pump PSI (NOTE 3)	Metered Nozzle PSI (NOTE 4)	Fuel lbs/hr (NOTE 5)	Fuel gal/hr (NOTE 6)
TSIO-360-D, DB	600	6.5 - 7.5		-	-
	2800 (36.0)	34.0 - 37.0	16.7 - 19.3	135 - 145	23.0 - 24.7
TSIO-360-E, EB, L/TSIO-360-E, EB	700	6.25 - 6.75		-	-
	2575 (40.0)	43.0 - 46.0	15.8 - 18.3	130 - 140	22.1 - 23.8
TSIO-360-F, FB	700	6.25 - 6.75		-	-
	2575 (41.0)	40.0 - 43.0	15.8 - 18.3	130 - 140	22.1 - 23.8
TSIO-360-G, GB	700	6.25 - 6.75		-	-
	2700 (40.0)	45.0 - 49.0	16.7 - 19.3	135 - 145	23.0 - 24.7
TSIO-360-H, HB	600	6.5 - 7.5		-	-
	2800 (34.5)	29.0 - 33.0	14.9 - 17.3	125 - 135	21.3 - 23.0
TSIO-360-JB	600	6.5 - 7.5		-	-
	2800 (37.0)	34.5 - 37.5	16.7 - 19.3	134 - 145	22.8 - 24.7
TSIO-360-KB, L/TSIO-360-KB	700	6.5 - 7.5		-	-
	2800 (40.0)	36.0 - 39.0	17.7 - 21.2	140 - 155	23.8 - 26.4
TSIO-360-LB	700	6.25 - 6.75		-	-
	2700 (40.0)	34.0 - 38.0	14.7 - 16.7	135 - 145	23.0 - 24.7
TSIO-360-MB	700	6.25 - 6.75		-	-
	2700 (36.0)	28.0 - 32.0	13.6 - 15.3	125 - 135	21.3 - 23.0
L/TSIO-360-RB	700	25 Minimum	-	-	-
See Note 1	2600 (38.0)	35.0 - 45.0	-	140 - 150	23.3 - 25.5

ISSUED			REVISED			 Teledyne Continental Motors, Inc. <small>A Teledyne Technologies Company</small> P.O. Box 90 Mobile Alabama • 251-438-3411	PAGE NO	REVISION
MO	DAY	YEAR	MO	DAY	YEAR		13 of 38 SID97-3	E
03	24	1997	06	17	2008			

TABLE 3. Fuel System Adjustment Values (cont'd)

IDLE AND FULL POWER FUEL PRESSURES AND FLOWS					
ENGINE SEE NOTE 7	Prop. RPM & (MAP)	Unmetered Pump PSI (NOTE 3)	Metered Nozzle PSI (NOTE 4)	Fuel lbs/hr (NOTE 5)	Fuel gal/hr (NOTE 6)
TSIO-360-SB	700	6.25 - 6.75		-	-
	2600 (39.0)	31 - 36	15.1 - 17.8	131 - 151	22.3 - 25.7
O-470-GCI	600	9.0 - 11.0		-	-
	2600	23.8 - 25.3	14.7 - 16.9	122 - 129	20.8 - 22.0
IO-470-C, G, P, R	600	9.0 - 11.0		-	-
	2600	24.7 - 27.7	14.8 - 17.3	123 - 130	21.0 - 22.1
IO-470-D, E, F, H L, M, N, S, U	600	9.0 - 11.0		-	-
	2625	25.0 - 28.0	15.0 - 17.5	124 - 131	21.1 - 22.3
IO-470-J, K	600	5.5 - 7.0		-	-
	2600	24.7 - 27.7	14.8 - 17.3	123 - 130	21.0 - 22.1
IO-470-V	600	6.5 - 7.5		-	-
	2625	28.3 - 29.8	17.8 - 18.8	123.5 - 131	21.0 - 22.3
IO-470-VO	600	6.5 - 7.5		-	-
	2625	28.8 - 31.0	17.8 - 18.8	132 - 137.5	22.5 - 23.4
GIO-470-A	450	9.0 - 11.0		-	-
	2400	26.0 - 28.0	15.5 - 16.5	145 - 155	24.7 - 26.4
TSIO-470-B, C, D	600	5.5 - 6.0		-	-
	2600 (35.0)	28.0 - 30.0	15.0 - 17.0	145 - 155	24.7 - 26.4
IO-520-A, J	600	9.0 - 11.0		-	-
	2700	29.0 - 32.0	15.9 - 18.2	136 - 146	23.2 - 24.9
IO-520-B, BA, BB C, CB	600	9.0 - 11.0		-	-
	2700	28.0 - 31.0	14.9 - 17.2	136 - 146	23.2 - 24.9
IO-520-D, F, K, L	600	9.0 - 11.0		-	-
	2850	30.0 - 33.0	17.0 - 19.4	143 - 153	24.4 - 26.1
IO-520-E	600	9.0 - 11.0		-	-
	2850	29.0 - 32.0	16.1 - 18.3	143 - 153	24.4 - 26.1

ISSUED			REVISED			 Teledyne Continental Motors, Inc. <small>A Teledyne Technologies Company</small> P.O. Box 90 Mobile Alabama • 251-438-3411	PAGE NO	REVISION
MO	DAY	YEAR	MO	DAY	YEAR		14 of 38 SID97-3	E
03	24	1997	06	17	2008			

TABLE 3. Fuel System Adjustment Values (cont'd)

IDLE AND FULL POWER FUEL PRESSURES AND FLOWS					
ENGINE SEE NOTE 7	Prop. RPM & (MAP)	Unmetered Pump PSI (NOTE 3)	Metered Nozzle PSI (NOTE 4)	Fuel lbs/hr (NOTE 5)	Fuel gal/hr (NOTE 6)
IO-520-M, MB	600	6.0 - 7.0		-	-
	2700	29.0 - 32.0	16.7 - 19.3	136 - 146	23.2 - 24.9
IO-520-P LIO-520-P	600	6.0 - 7.0		-	-
	2500	26.2 - 26.9	14.3 - 16.2	130 - 140	22.1 - 23.9
TSIO-520-AE, L/TSIO-520-AE	600	7.5 - 8.5		-	-
	2400 (32.5)	34.5 - 38.0	15.2 - 16.5	160 - 165	27.3 - 28.1
TSIO-520-AF	600	5.5 - 6.5		-	-
	2700 (35.5)	35.0 - 39.0	18.4 - 19.9	180 - 186	30.7 - 31.7
TSIO-520-B, BB	600	5.5 - 7.0		-	-
	2700 (32.0)	29.0 - 32.0	16.0 - 17.9	165 - 175	28.1 - 29.8
TSIO-520-BE	600	5.5 - 7.0		-	-
	2600 (38.0)	25.0 - 28.0	12.7 - 14.1	214 - 224	36.5 - 38.2
TSIO-520-C, H	600	5.5 - 7.0		-	-
	2700 (32.5)	29.0 - 32.0	15.3 - 17.2	160 - 170	27.3 - 29.0
TSIO-520-CE	600	5.5 - 6.5		-	-
	2700 (37.0)	33.0 - 36.0	16.2 - 18.0	215 - 225	36.6 - 38.3
TSIO-520-D, DB	600	5.5 - 7.0		-	-
	2700 (32.5)	29.0 - 32.0	13.3 - 15.1	160 - 170	27.3 - 29.0
TSIO-520-E, EB	600	5.5 - 6.5		-	-
	2700 (34.5)	31.0 - 34.0	15.6 - 17.7	175 - 185	29.8 - 31.5

ISSUED			REVISED			 Teledyne Continental Motors, Inc. <small>A Teledyne Technologies Company</small> P.O. Box 90 Mobile Alabama • 251-438-3411	PAGE NO	REVISION
MO	DAY	YEAR	MO	DAY	YEAR		15 of 38 SID97-3	E
03	24	1997	06	17	2008			

TABLE 3. Fuel System Adjustment Values (cont'd)

IDLE AND FULL POWER FUEL PRESSURES AND FLOWS					
ENGINE SEE NOTE 7	Prop. RPM & (MAP)	Unmetered Pump PSI (NOTE 3)	Metered Nozzle PSI (NOTE 4)	Fuel lbs/hr (NOTE 5)	Fuel gal/hr (NOTE 6)
TSIO-520-G	600	5.5 - 6.5		-	-
	2700 (35.0)	31.0 - 34.0	15.8 - 17.6	181 - 191	30.8 - 32.5
TSIO-520-J, JB	600	5.5 - 6.5		-	-
	2700 (36.0)	31.0 - 34.0	16.9 - 18.7	170 - 178	29.0 - 30.3
TSIO-520-K, KB	600	5.5 - 7.0		-	-
	2700 (33.0)	29.0 - 32.0	15.1 - 17.4	163 - 175	27.8 - 29.8
TSIO-520-L, LB SEE NOTE 1	600	25 - Minimum	-	-	-
	2700 (38.0)	45.0 - 55.0	-	180 - 190	30.7 - 32.4
TSIO-520-M, R	600	5.5 - 6.5		-	-
	2700 (36.5)	33.0 - 37.0	16.9 - 19.9	170 - 186	29.0 - 31.7
TSIO-520-N, NB	600	5.5 - 6.5		-	-
	2700 (38.0)	32.0 - 35.0	16.9 - 19.9	170 - 186	28.9 - 31.7
TSIO-520-P	600	5.5 - 6.5		-	-
	2700 (36.5)	33.0 - 37.0	18.4 - 19.9	180 - 186	30.7 - 31.7
TSIO-520-T	600	5.5 - 6.5		-	-
	2700 (39.5)	33.0 - 37.0	16.3 - 18.1	185 - 195	31.5 - 33.2
TSIO-520-UB	600	5.5 - 6.5		-	-
	2700 (36.0)	33.0 - 37.0	14.4 - 16.0	195 - 205	33.2 - 34.9
TSIO-520-VB	600	5.6 - 6.5		-	-
	2700 (40.5)	36.0 - 39.5	16.9 - 18.7	200 - 210	34.1 - 35.8

ISSUED			REVISED			 Teledyne Continental Motors, Inc. <small>A Teledyne Technologies Company</small> P.O. Box 90 Mobile Alabama • 251-438-3411	PAGE NO	REVISION
MO	DAY	YEAR	MO	DAY	YEAR		16 of 38 SID97-3	E
03	24	1997	06	17	2008			

TABLE 3. Fuel System Adjustment Values (cont'd)

IDLE AND FULL POWER FUEL PRESSURES AND FLOWS					
ENGINE SEE NOTE 7	Prop. RPM & (MAP)	Unmetered Pump PSI (NOTE 3)	Metered Nozzle PSI (NOTE 4)	Fuel lbs/hr (NOTE 5)	Fuel gal/hr (NOTE 6)
TSIO-520-WB SEE NOTE 1	600	25 - Minimum	-	-	-
	2700 (39.5)	45.0 - 55.0	-	190 - 200	32.4 - 34.1
GTSIO-520-C	525	4.0 - 7.0		-	-
	2400 (34.5)	30.0 - 33.0	16.5 - 17.5	215 - 225	36.6 - 38.3
GTSIO-520-D, H	467	4.0 - 7.0		-	-
	2267 (39.5)	30.5 - 35.0	15.7 - 17.3	250 - 260	42.6 - 44.3
GTSIO-520-F, K SEE NOTE 1	600	6.75 - 7.25		-	-
	2267 (44.5)	38.0 - 41.0	17.4 - 18.8	300 - 310	51.1 - 52.8
GTSIO-520-L	467	4.0 - 7.0		-	-
	2234 (39.0)	29.5 - 35.0	16.4 - 17.9	255 - 265	43.4 - 45.1
GTSIO-520-M	467	4.0 - 7.0		-	-
	2234 (40.0)	29.5 - 35.0	16.4 - 17.9	255 - 265	43.4 - 45.1
GTSIO-520-N SEE NOTE 1	467	4.0 - 7.0		-	-
	2234 (39.0)	29.5 - 35.0	16.4 - 17.9	255 - 265	43.4 - 45.1
IO-550-A →	600	8.0 - 10.0		-	-
	2700	32.0 - 36.0	17.7 - 20.0	142 - 150	24.2 - 25.6
→ Engines with Altitude Compensating fuel pumps See Note 2 page 18 of 38.					
IO-550-B ↓ SEE NOTE 2	600	8.0 - 10.0		-	-
	2700	29.2 - 36.2	16.5 - 18.4	146 - 156	24.9 - 26.6
↓ Engines with Altitude Compensating fuel pumps See Note 2 page 18 of 38.					
IO-550-C ° SEE NOTE 2	600	8.0 - 10.0		-	-
	2700	31.6 - 37.8	17.6 - 19.6	152 - 160	25.9 - 27.3
° Engines with Altitude Compensating fuel pumps See Note 2 page 18 of 38.					

ISSUED			REVISED			 Teledyne Continental Motors, Inc. <small>A Teledyne Technologies Company</small> P.O. Box 90 Mobile Alabama • 251-438-3411	PAGE NO	REVISION
MO	DAY	YEAR	MO	DAY	YEAR		17 of 38 SID97-3	E
03	24	1997	06	17	2008			

TABLE 3. Fuel System Adjustment Values (cont'd)

IDLE AND FULL POWER FUEL PRESSURES AND FLOWS					
ENGINE SEE NOTE 7	Prop. RPM & (MAP)	Unmetered Pump PSI (NOTE 3)	Metered Nozzle PSI (NOTE 4)	Fuel lbs/hr (NOTE 5)	Fuel gal/hr (NOTE 6)
IO-550-D, E, F, L ± SEE NOTE 2	600	8.0 - 10.0		-	-
	2700	32.0 - 36.0	17.2 - 20.0	143 - 155	24.4 - 26.4
± Engines with Altitude Compensating fuel pumps See Note 2 page 18 of 38.					
IO-550-G	600	8.0 - 10.0		-	-
	2500	22.0 - 26.0	14.7 - 16.0	125 - 130	21.3 - 22.1
IO-550-N	600	8 - 10		-	-
	2700	28 - 32	19 - 21.3	150 - 160	25.6 - 27.3
IO-550-P	600	8 - 10		-	-
	2700	28 - 32	19 - 21.3	150 - 160	25.6 - 27.3
IO-550-R	600	8 - 10		-	-
	2700	28 - 32	19 - 21.3	150 - 160	25.6 - 27.3
GIO-550-A See NOTE 1	600	25-Minimum	-	-	-
	2267	45 - 55	-	175 - 185	29.8 - 31.5
TSIO-550-B	SEE	Maintenance	Manual	M-18	
TSIO-550-C	SEE	Maintenance	Manual	M-18	
TSIO-550-E	SEE	Maintenance	Manual	M-18	
TSIO-550-G	SEE	Maintenance	Manual	M-18	
TSIO-550-G	600	7.0-9.0			
MOONEY	2500 (33.5)	20.0-23.0	10.4-11.6	177-180	30.0-30.7
Consult current Mooney Aircraft Maintenance Manual for any changes to fuel setup procedures or values					
TSIOL-550-A	600	5.5 - 6.5			
	2600 (35.0)	32.5 - 35.5	17.0 - 19.0	170 - 180	29.0 - 30.7

ISSUED			REVISED			 Teledyne Continental Motors, Inc. <small>A Teledyne Technologies Company</small> P.O. Box 90 Mobile Alabama • 251-438-3411	PAGE NO	REVISION
MO	DAY	YEAR	MO	DAY	YEAR		18 of 38 SID97-3	E
03	24	1997	06	17	2008			

TABLE 3. Fuel System Adjustment Values (cont'd)

IDLE AND FULL POWER FUEL PRESSURES AND FLOWS					
ENGINE SEE NOTE 7	Prop. RPM & (MAP)	Unmetered Pump PSI (NOTE 3)	Metered Nozzle PSI (NOTE 4)	Fuel lbs/hr (NOTE 5)	Fuel gal/hr (NOTE 6)
TSIOL-550-B	600	6.0 - 8.0	-	-	-
	2700 (35.0)	36.0 - 40.0	20.0 - 22.5	175 - 185	29.8 - 31.5
TSIOL-550-C	600	6.0 - 8.0	-	-	-
	2600 (39.5)	37.0 - 40.0	15.0 - 16.5	204 - 216	34.8 - 36.8
6-285 (TIARA)	See latest revision of Teledyne Continental Motors Service Bulletin M79-4.				

- NOTE 1: Refer to the aircraft manufacturer's instructions for adjustment procedures.
- NOTE 2: Flight test required to verify fuel flow vs. pressure altitude values are within the limits specified. See applicable Tables 5 through 12 and Charts 2 through 9 for specified values by engine model.
- NOTE 3: FULL POWER unmetered fuel pump pressure limits are provided for reference only. Use metered fuel pressure specifications for adjustments at full power.
- NOTE 4: Use for full power, maximum RPM adjustment only. All other parameters for reference only, see note → above.
- NOTE 5: May be determined using a calibrated in-line flow measuring device. Otherwise use metered fuel pressure specifications. Refer to Aircraft Manufacturer's Maintenance Manual for method of verifying accuracy of fuel flow indicator.
- NOTE 6: This engine installed in Cirrus SR20 aircraft. IO-360-ES (6) B engine has been de-rated by Cirrus from original 210 HP at 2800 RPM to 200 HP at 2700 RPM. Engine data plate reflects original TC and PC data of 210 HP at 2800 RPM. Refer to Cirrus SR20 Maintenance Manual and Pilots Operating Handbook.
- NOTE 7: The setup procedures contained in this bulletin are only for use on engines that have not been modified from their original configuration as shipped from the factory by Teledyne Continental Motors. Engines which have been modified by the installation of aftermarket components such as turbo-normalizing systems, turbocharging systems, intercoolers, after-coolers, fuel nozzles, etc, whether by STC or field approval, must use the instructions provided by the STC holder or installer. TCM will not accept any responsibility or liability for any modified engine set up in accordance with procedures contained in this Service Information Directive.

**TABLE 4
IO-240-A,B Without Altitude Compensating (Aneroid Equipped) Pump**

ISSUED			REVISED			 Teledyne Continental Motors, Inc. <small>A Teledyne Technologies Company</small> P.O. Box 90 Mobile Alabama • 251-438-3411	PAGE NO	REVISION
MO	DAY	YEAR	MO	DAY	YEAR		19 of 38 SID97-3	E
03	24	1997	06	17	2008			

FULL THROTTLE STATIC RPM METERED FUEL PRESSURE SPECIFICATIONS

FULL THROTTLE STATIC ENGINE RPM	NOMINAL METERED FUEL PRESSURE	ALLOWED VARIATION
1800 RPM	7.8	± 0.3
1850 RPM	8.1	± 0.3
1900 RPM	8.3	± 0.3
1950 RPM	8.6	± 0.3
2000 RPM	8.8	± 0.3
2050 RPM	9.1	± 0.3
2100 RPM	9.4	± 0.3
2150 RPM	9.6	± 0.3
2200 RPM	9.9	± 0.3
2250 RPM	10.2	± 0.3
2300 RPM	10.5	± 0.3
2350 RPM	10.8	± 0.3
2400 RPM	11.2	± 0.3

CHART 1

ISSUED			REVISED			 Teledyne Continental Motors, Inc. <small>A Teledyne Technologies Company</small> P.O. Box 90 Mobile Alabama • 251-438-3411	PAGE NO	REVISION
MO	DAY	YEAR	MO	DAY	YEAR		20 of 38 SID97-3	E
03	24	1997	06	17	2008			

IO-240-B with Altitude Compensating (Aneroid Equipped) Fuel Pump and Standard Fuel Manifold Valve

Idle (Step 1)

Set Unmetered pump pressure and RPM rise at 1000 +/- 25 rpm to 9.6 +/- 0.2 psi (sea level / standard day). If pressure altitude is different from sea level, determine required unmetered pressure setting from the plot below (Reference Figure 15)

NOTE: Pressure altitude must be used for the figures below when determining fuel system set-up values. To determine pressure altitude, set your altimeter to 29.92 in hg, and the altimeter will indicate your pressure altitude.

IO240B Idle Unmetered Pressure Altitude Plot @ 1000 RPM

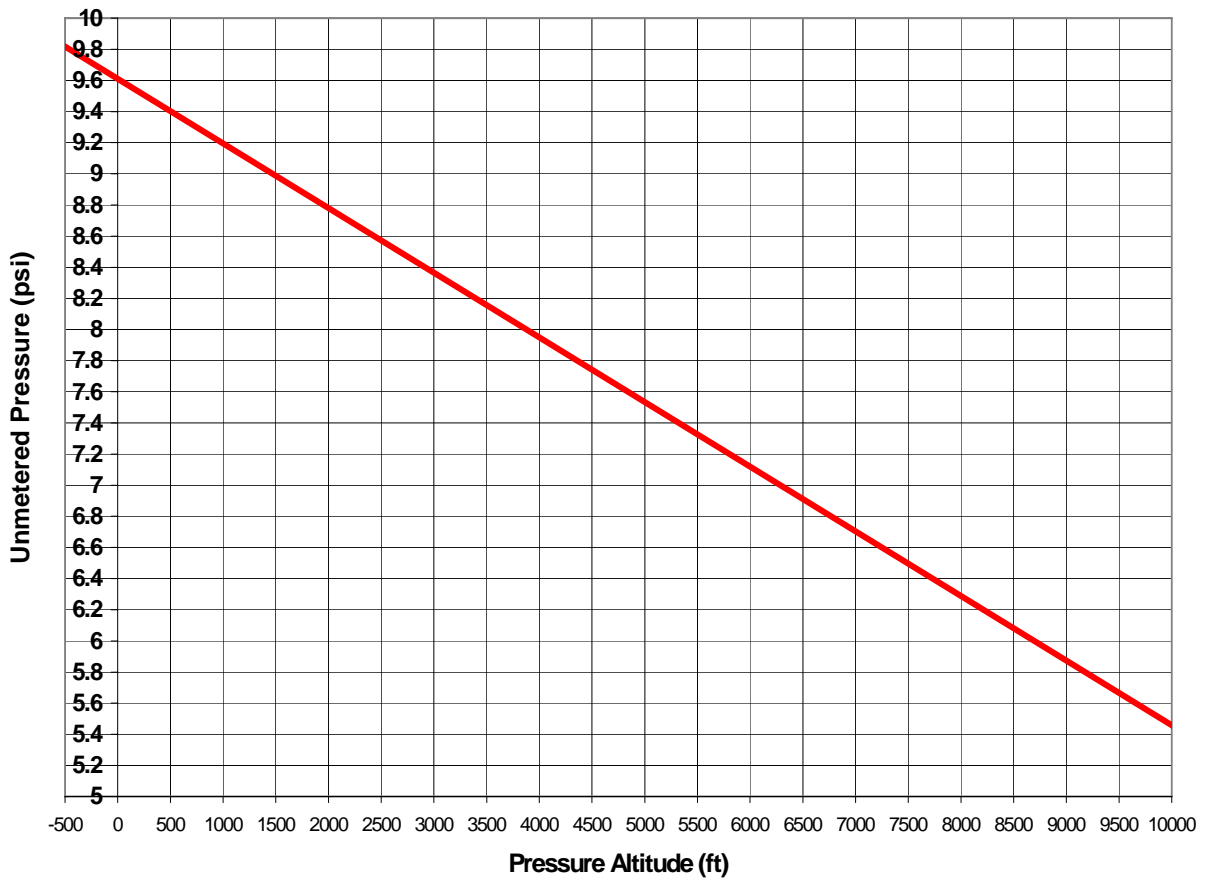

Adjust idle mixture screw to set RPM rise during mixture check at 1000 rpm to 20 - 50 rpm.

ISSUED			REVISED			 Teledyne Continental Motors, Inc. <small>A Teledyne Technologies Company</small> P.O. Box 90 Mobile Alabama • 251-438-3411	PAGE NO	REVISION
MO	DAY	YEAR	MO	DAY	YEAR		21 of 38 SID97-3	E
03	24	1997	06	17	2008			

CHART 1 (Con't)

Full Throttle (Step 2)

Adjust the aneroid rod to obtain the metered nozzle pressure (+/- 0.3 psi) at pressure altitude and RPM per the chart above. Turn clockwise to decrease pressure and counter-clockwise to increase pressure. After adjustment, recheck idle unmetered pressure setting using the instructions in step 1 of this chart. (Reference Figure 15)

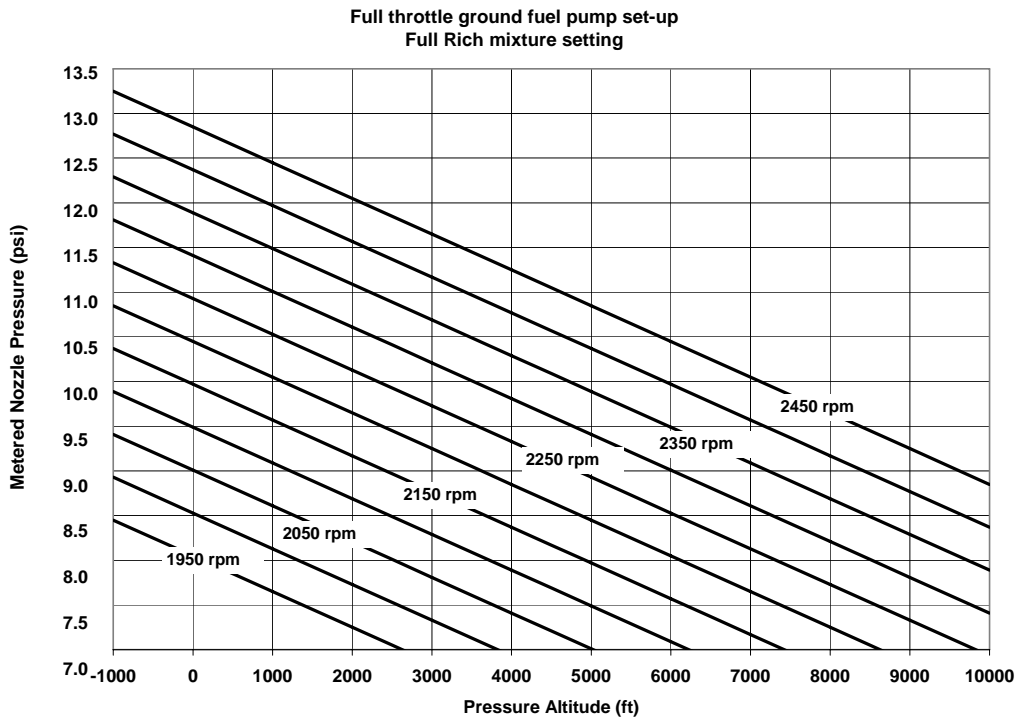

NOTE: At conclusion of setup, reset the idle speed to 850 RPM (+/- 25 RPM) and verify idle cutoff mixture rise, acceleration / deceleration without excessive idle speed dip, and idle stability.

Table 5

ISSUED			REVISED			 Teledyne Continental Motors, Inc. <small>A Teledyne Technologies Company</small> P.O. Box 90 Mobile Alabama • 251-438-3411	PAGE NO	REVISION
MO	DAY	YEAR	MO	DAY	YEAR		22 of 38 SID97-3	E
03	24	1997	06	17	2008			

Flight Test Verification, IO-240-B equipped with Altitude Compensating Pump and Standard Fuel Manifold Valve

This test is for reference only, actual RPM may vary due to the fixed pitch prop.

NOTE: Pressure altitude must be used for the table and chart below when determining fuel system set-up values. To determine pressure altitude, prior to take-off set your altimeter to 29.92 in hg, and the altimeter will indicate your pressure altitude.

IO-240-B Engine with Aneroid Fuel Pump, Full Throttle, Full Rich Mixture @ 2450 RPM						
Pressure Altitude (Set Altimeter at 29.92 in. Hg) (feet)	Fuel Flow (lbs/hr)		Fuel Flow (gals/hr)		Metered Fuel Pressure PSID	
	Minimum	Maximum	Minimum	Maximum	Minimum	Maximum
Sea Level	53.5	60	9.1	10.2	10.8	14.8
1,000	50.2	56.7	8.5	9.7	9.5	13.3
2,000	46.7	53.2	7.9	9.1	8.7	12.3
3,000	43.9	50.4	7.5	8.6	8.1	11.5
4,000	40.8	47.3	6.9	8.0	7.6	10.8
5,000	38.4	44.9	6.5	7.6	7.2	10.2
6,000	36.9	43.4	6.3	7.4	6.8	9.6
8,000	34.0	40.5	5.8	6.9	6.5	9.1
10,000	32.1	38.6	5.5	6.6	6.3	8.7
12,000	31.1	37.6	5.3	6.4	6.2	8.4
14,000	30.4	36.9	5.2	6.3	6.2	8.2

CHART 2

Typical IO240B (with altitude compensating fuel pump) fuel flow leaning curve during flight test.

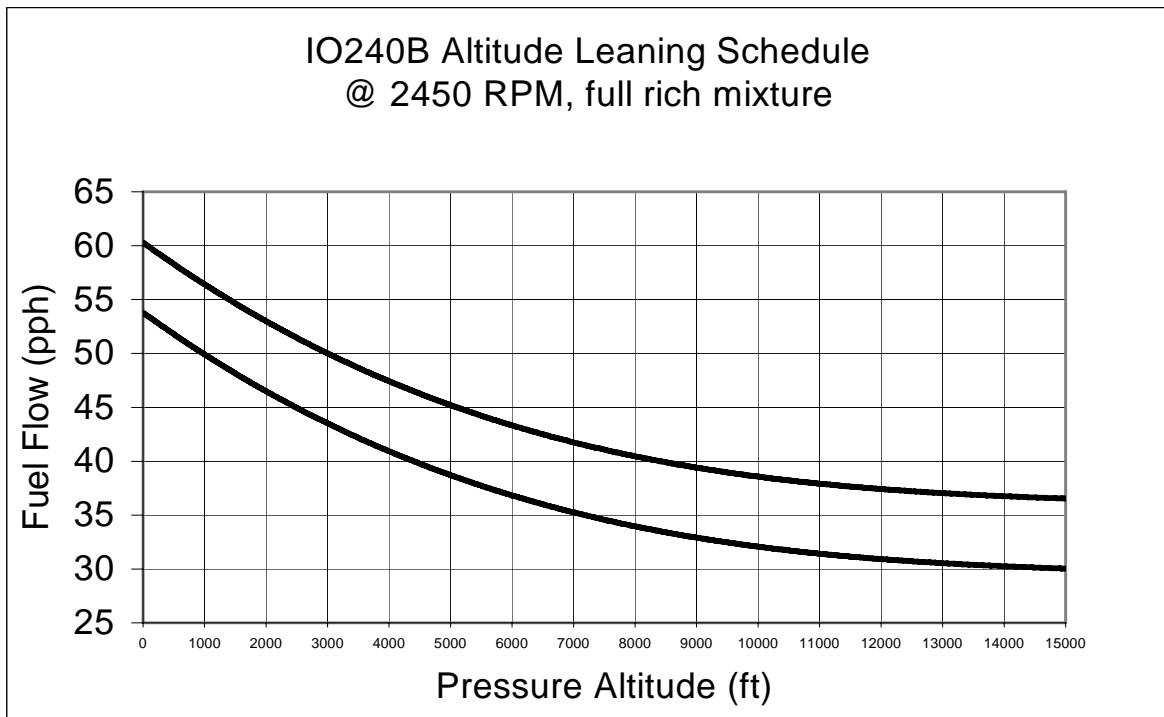

TABLE 6. ALTITUDE FUEL SCHEDULE

ISSUED			REVISED			 Teledyne Continental Motors, Inc. <small>A Teledyne Technologies Company</small> P.O. Box 90 Mobile Alabama • 251-438-3411	PAGE NO	REVISION
MO	DAY	YEAR	MO	DAY	YEAR		23 of 38 SID97-3	E
03	24	1997	06	17	2008			

IO-360-DB ENGINE FULL OPEN THROTTLE, FULL RICH MIXTURE BHP @ 2800 RPM						
Pressure Altitude (Set Altimeter at 29.92 in. Hg.)	Fuel Flow (lbs/hr)		Fuel Flow (gals/hr)		Metered Fuel Pressure PSID	
	Min.	Max.	Min.	Max.	Min.	Max.
Sea Level	102.9	112.9	17.5	19.2	16.0	18.8
1,000	98.4	108.4	16.8	18.5	15.0	17.8
2,000	94.1	104.1	16.0	17.7	14.1	16.8
3,000	90.0	100.0	15.3	17.0	13.3	15.9
4,000	86.1	96.1	14.7	16.4	12.6	15.1
5,000	82.3	92.3	14.0	15.7	11.9	14.4
6,000	78.8	88.8	13.4	15.1	11.3	13.7
8,000	72.2	82.2	12.3	14.0	10.2	12.5
10,000	66.4	76.4	11.3	13.0	9.3	11.5
12,000	61.3	71.3	10.4	12.1	8.6	10.7
14,000	56.9	66.9	9.7	11.4	8.0	10.0
16,000	53.3	63.3	9.1	10.8	7.5	9.5

Gasoline = 5.87 lbs per gallon @ 70° F.
IO-360-DB Installed in T-41 ACFT Refer to Cessna SL 81-2 date 28 July 1981 for amplified instructions.

Altitude Leaning Schedule
IO-360-DB-(34)

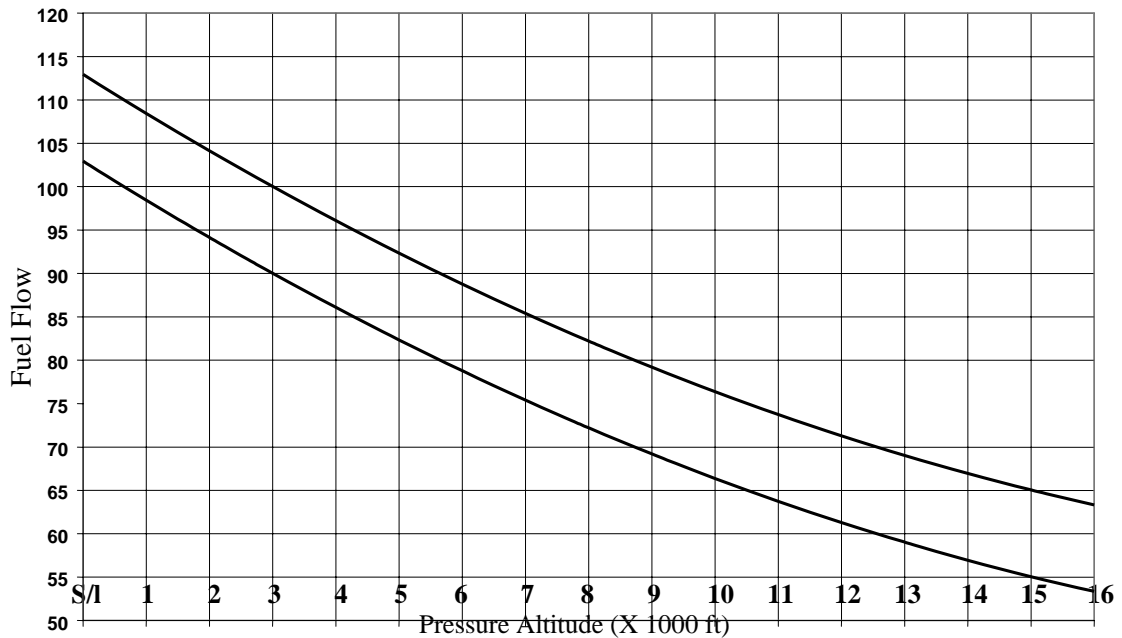

CHART 3

ISSUED			REVISED			 Teledyne Continental Motors, Inc. <small>A Teledyne Technologies Company</small> P.O. Box 90 Mobile Alabama • 251-438-3411	PAGE NO	REVISION
MO	DAY	YEAR	MO	DAY	YEAR		24 of 38 SID97-3	E
03	24	1997	06	17	2008			

TABLE 7. ALTITUDE FUEL SCHEDULE

IO-360 ES ENGINE FULL OPEN THROTTLE, FULL RICH MIXTURE BHP @ 2800 RPM						
Pressure Altitude (Set Altimeter at 29.92 in. Hg.)	Fuel Flow (lbs/hr)		Fuel Flow (gals/hr)		Metered Fuel Pressure PSID	
	Min.	Max.	Min.	Max.	Min.	Max.
Sea Level	100.0	107.0	17.0	18.1	14.3	16.5
1,000	97.7	103.7	16.6	17.7	13.9	15.8
2,000	93.7	99.7	16.0	17.0	13.1	14.9
3,000	90.3	96.3	15.4	16.4	12.3	14.1
4,000	87.3	93.3	14.9	15.9	11.7	13.6
5,000	85.0	91.0	14.5	15.5	11.5	13.2
6,000	83.3	89.3	14.2	15.2	11.1	12.8
8,000	80.0	86.0	13.6	14.7	10.6	12.2
10,000	77.3	83.3	13.2	14.2	10.1	11.8
12,000	74.4	80.4	12.7	13.7	9.6	11.2
14,000	71.3	77.3	12.1	13.2	9.2	10.7
16,000	69.3	75.3	11.8	12.8	8.9	10.3
Gasoline = 5.87 lbs per gallon @ 70° F.						

ALTITUDE LEANING SCHEDULE
IO-360-ES
 2800 R.P.M. and FULL RICH MIXTURE
 FULL OPEN THROTTLE

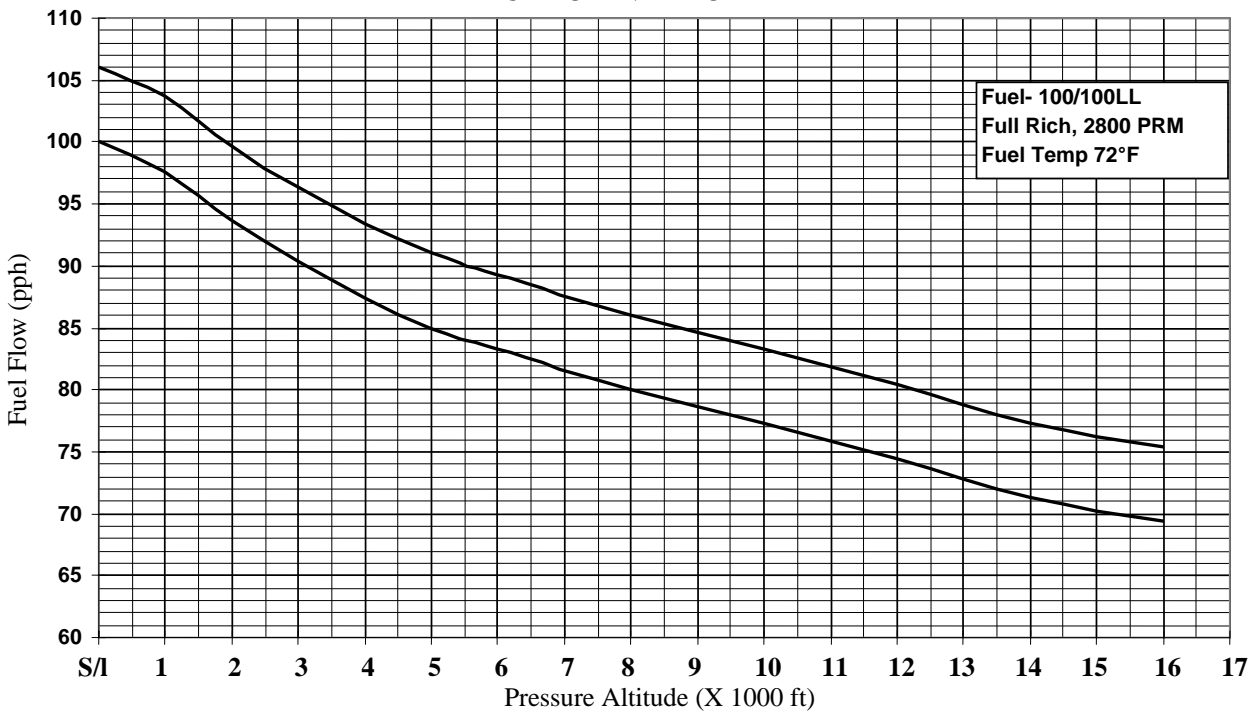

CHART 4

ISSUED			REVISED			 Teledyne Continental Motors, Inc. <small>A Teledyne Technologies Company</small> P.O. Box 90 Mobile Alabama • 251-438-3411	PAGE NO	REVISION
MO	DAY	YEAR	MO	DAY	YEAR		25 of 38 SID97-3	E
03	24	1997	06	17	2008			

TABLE 8. ALTITUDE FUEL SCHEDULE

IO-360 ES ENGINE FULL OPEN THROTTLE, FULL RICH MIXTURE BHP @ 2700 RPM						
Pressure Altitude (Set Altimeter at 29.92 in. Hg.)	Fuel Flow (lbs/hr)		Fuel Flow (gals/hr)		Metered Fuel Pressure PSID	
	Min.	Max.	Min.	Max.	Min.	Max.
Sea Level	96.0	102.0	16.4	17.4	13.4	15.1
1,000	94.5	99.7	16.0	17.0	13.1	15.0
2,000	89.5	95.7	15.3	16.3	12.2	14.3
3,000	86.3	92.3	14.7	15.7	12.0	13.5
4,000	83.3	89.3	14.2	15.2	11.5	13.0
5,000	81.0	87.0	13.8	14.8	11.0	12.5
6,000	79.3	85.3	13.5	14.5	10.8	12.3
8,000	76.0	82.0	12.9	14.0	10.3	11.8
10,000	73.3	79.3	12.5	13.5	9.8	11.3
12,000	70.4	76.4	12.0	13.0	9.3	10.8
14,000	67.3	73.3	11.5	12.5	8.8	10.3
16,000	65.3	71.3	11.1	12.1	8.5	10.0

Gasoline = 5.87 lbs. per gallon @ 70° F.

ALTITUDE LEANING SCHEDULE

IO-360-ES (6) AT 2700 RPM
FULL RICH MIXTURE & FULL OPEN THROTTLE

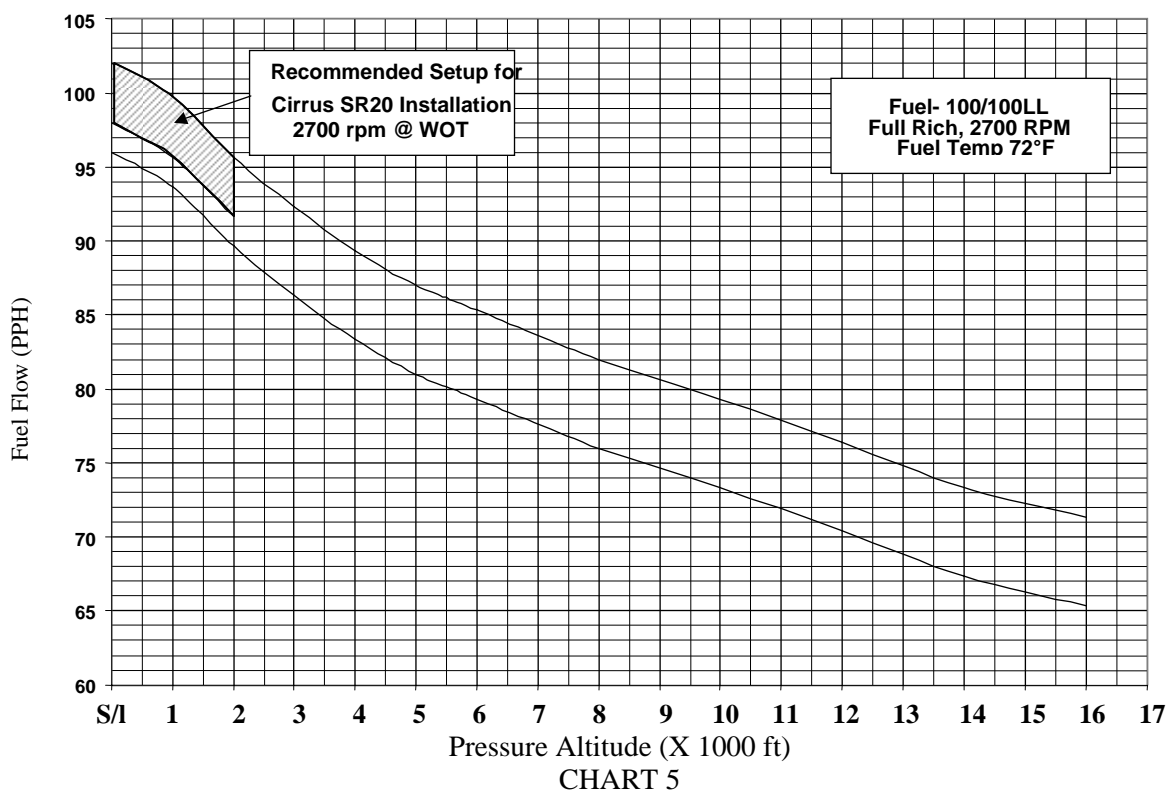

ISSUED			REVISED			 Teledyne Continental Motors, Inc. <small>A Teledyne Technologies Company</small> P.O. Box 90 Mobile Alabama • 251-438-3411	PAGE NO	REVISION
MO	DAY	YEAR	MO	DAY	YEAR		26 of 38 SID97-3	E
03	24	1997	06	17	2008			

TABLE 9. ALTITUDE FUEL SCHEDULE

IO-550-A ENGINE FULL OPEN THROTTLE, FULL RICH MIXTURE 300 BHP @ 2700 RPM						
Pressure Altitude (Set Altimeter at 29.92 in. Hg.)	Fuel Flow (lbs/hr)		Fuel Flow (gals/hr)		Metered Fuel Pressure PSID	
	Min.	Max.	Min.	Max.	Min.	Max.
Sea Level	142	150	24.2	25.6	16.5	17.2
1000	141	149	24.0	25.4	16.3	17.1
2,000	138	146	23.5	24.9	15.9	16.6
3000	133	141	22.6	24.0	15.1	15.7
4,000	128	136	21.8	23.2	14.3	14.9
5000	123	131	21.0	22.3	13.6	14.1
6,000	120	128	20.4	21.8	13.2	13.7
8,000	113	121	19.2	20.6	12.3	12.7
10,000	108	116	18.4	19.8	11.6	12.1
12,000	103	111	17.5	18.9	11.0	11.4
14,000	98	106	16.7	18.1	10.4	10.7

Gasoline = 5.87 lbs per gallon @ 70° F

Altitude Leaning Schedule
IO-550-A
Full Rich, 2700 RPM

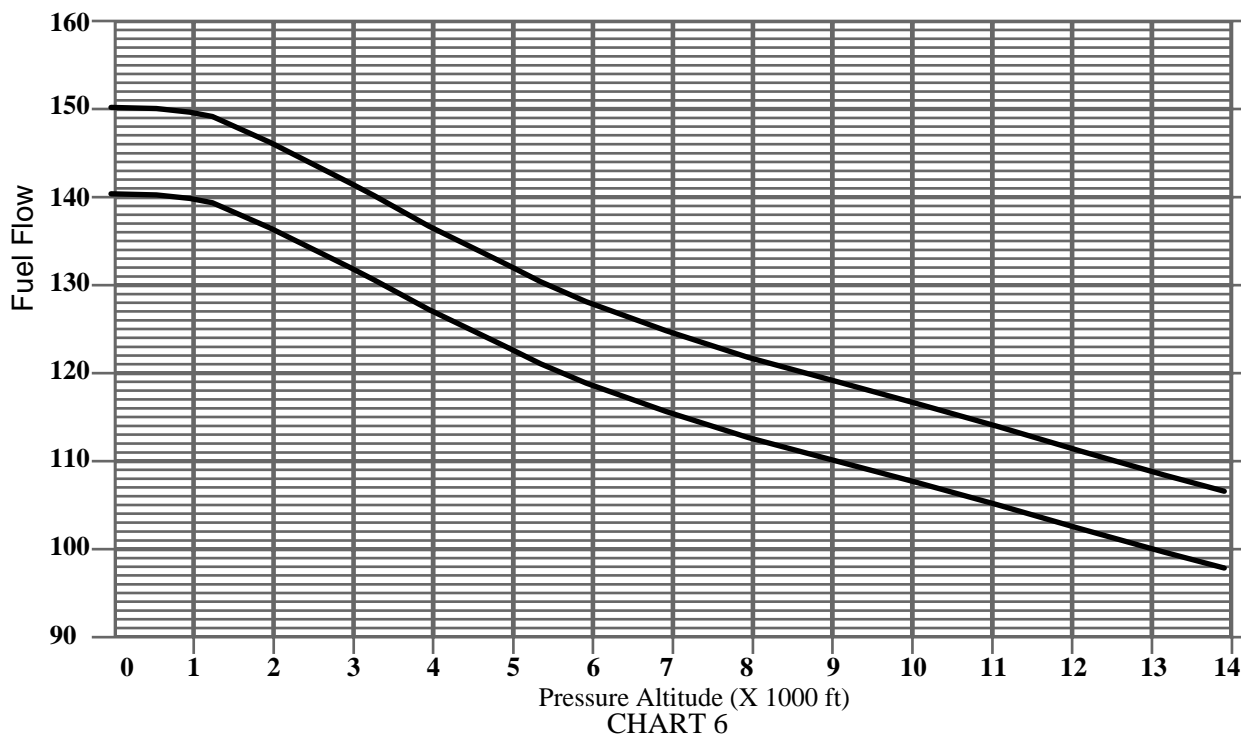

ISSUED			REVISED			 Teledyne Continental Motors, Inc. <small>A Teledyne Technologies Company</small> P.O. Box 90 Mobile Alabama • 251-438-3411	PAGE NO	REVISION
MO	DAY	YEAR	MO	DAY	YEAR		27 of 38 SID97-3	E
03	24	1997	06	17	2008			

TABLE 10. ALTITUDE FUEL SCHEDULE

IO-550-B ENGINE FULL OPEN THROTTLE, FULL RICH MIXTURE 300 BHP @ 2700 RPM						
Pressure Altitude (Set Altimeter at 29.92 in. Hg.)	Fuel Flow (lbs/hr)		Fuel Flow (gals/hr)		Metered Fuel Pressure PSID	
	Min.	Max.	Min.	Max.	Min.	Max.
Sea Level	146	156	24.9	26.6	17.2	18.3
1000	145.5	155.5	24.8	26.5	17.1	18.2
2,000	145	155	24.7	26.4	17.0	18.1
3000	144	154	24.5	26.3	16.9	17.9
4,000	142	152	24.2	25.9	16.5	17.5
5000	139	149	23.7	25.4	16.1	17.0
6,000	135.5	145.5	23.1	24.8	15.5	16.5
8,000	127	137	21.6	23.3	14.2	15.1
10,000	117	127	19.9	21.6	12.8	13.6
12,000	110	120	18.7	20.4	11.9	12.6
14,000	105	115	17.9	19.6	11.3	11.9
Gasoline = 5.87 lbs per gallon @ 70° F.						

Altitude Leaning Schedule
IO-550-B
Full Rich, 2700 RPM

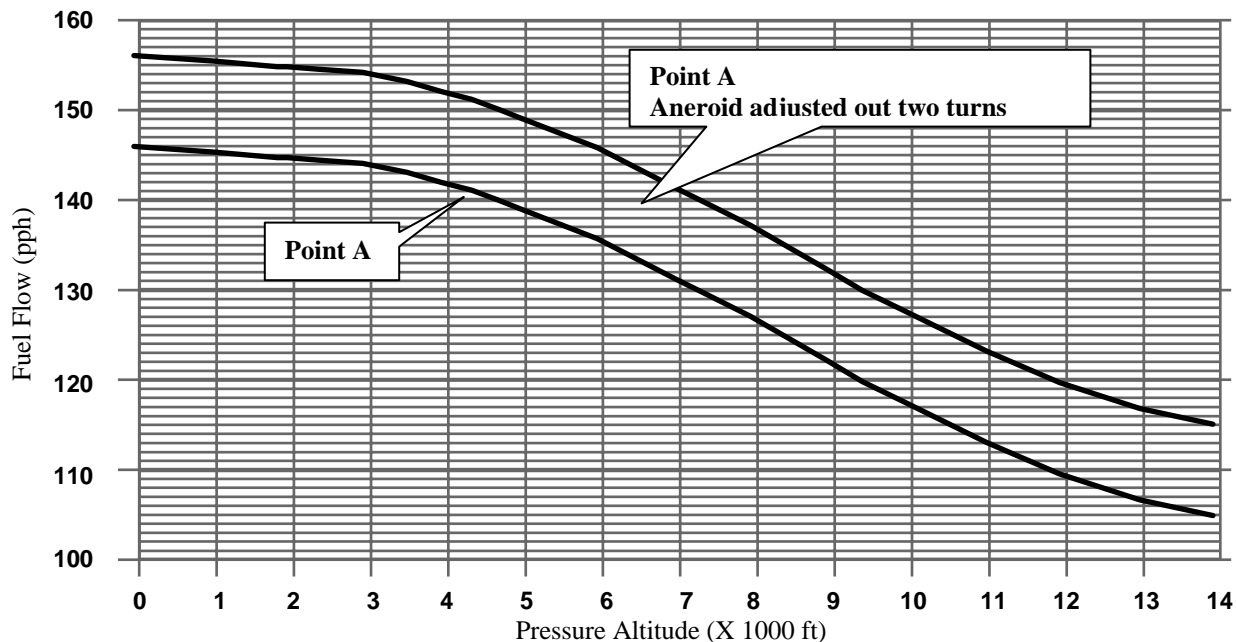

CHART 7

ISSUED			REVISED			PAGE NO	REVISION
MO	DAY	YEAR	MO	DAY	YEAR		
03	24	1997	06	17	2008	28 of 38 SID97-3	E



Teledyne Continental Motors, Inc.
A Teledyne Technologies Company
P.O. Box 90 Mobile Alabama • 251-438-3411

TABLE 11. ALTITUDE FUEL SCHEDULE

IO-550-C ENGINE FULL OPEN THROTTLE, FULL RICH MIXTURE 300 BHP @ 2700 RPM						
Pressure Altitude (Set Altimeter at 29.92 in. Hg.)	Fuel Flow (lbs/hr)		Fuel Flow (gals/hr)		Metered Fuel Pressure PSID	
	Min.	Max.	Min.	Max.	Min.	Max.
Sea Level	152	160	25.9	27.2	18.2	18.9
1000	151	159	25.7	27.1	18.0	18.7
2,000	148	156	25.2	26.6	17.5	18.2
3000	143	151	24.4	25.7	16.7	17.4
4,000	138	146	23.5	24.9	15.9	16.5
5000	134	142	22.8	24.2	15.3	15.9
6,000	130	138	22.1	23.5	14.7	15.3
8,000	123	131	21.0	22.3	13.6	14.1
10,000	118	126	20.1	21.5	12.9	13.4
12,000	113	121	19.3	20.6	12.3	12.7
14,000	108	116	18.4	19.8	11.7	12.1

Gasoline = 5.87 lbs per gallon @ 70° F.

Altitude Leaning Schedule
IO-550-C
Full Rich, 2700 RPM

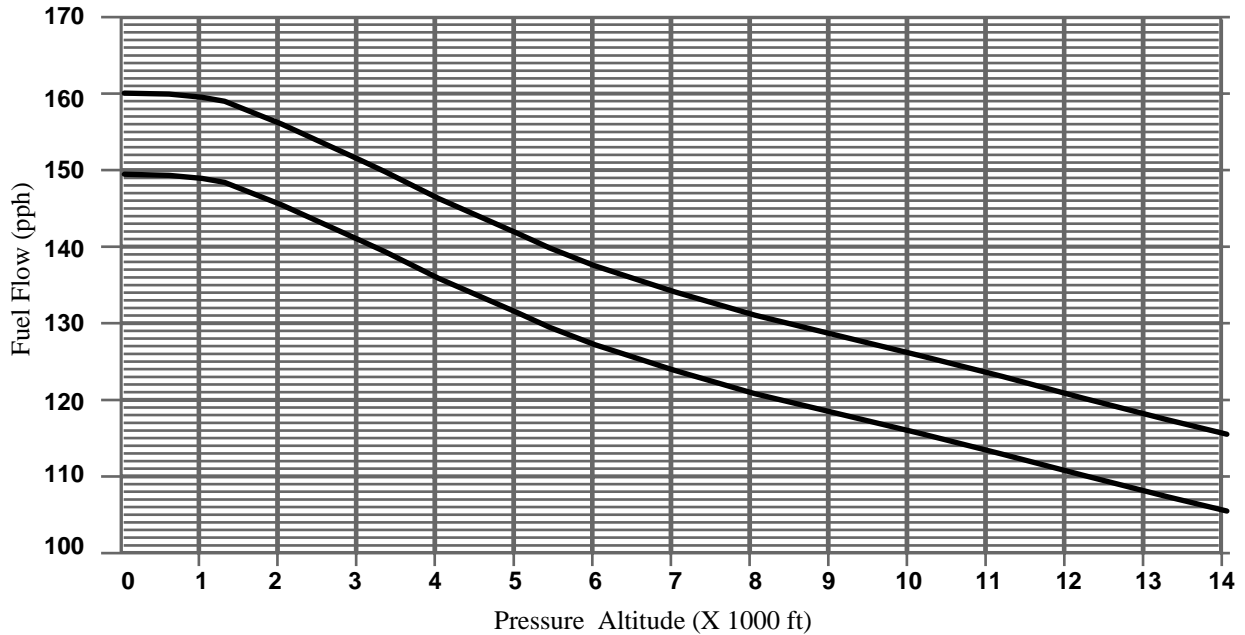

CHART 8

ISSUED			REVISED			 Teledyne Continental Motors, Inc. <small>A Teledyne Technologies Company</small> P.O. Box 90 Mobile Alabama • 251-438-3411	PAGE NO	REVISION
MO	DAY	YEAR	MO	DAY	YEAR		29 of 38 SID97-3	E
03	24	1997	06	17	2008			

TABLE 12. ALTITUDE FUEL SCHEDULE

IO-550-D,-E, F, L ENGINE FULL OPEN THROTTLE, FULL RICH MIXTURE 300 BHP @ 2700 RPM						
Pressure Altitude (Set Altimeter at 29.92 in. Hg.)	Fuel Flow (lbs/hr)		Fuel Flow (gals/hr)		Metered Fuel Pressure PSID	
	Min.	Max.	Min.	Max.	Min.	Max.
Sea Level	143	155	24.4	26.4	17.2	20.0
1000	142.5	154.5	24.3	26.3	17.1	19.9
2,000	142	154	24.2	26.2	17.0	19.8
3000	141	153	24.0	26.1	16.9	19.6
4,000	139	151	23.7	25.7	16.5	19.2
5000	136	148	23.2	25.2	16.0	18.7
6,000	133	145	22.6	24.7	15.5	18.2
8,000	124	136	21.1	23.2	14.0	16.6
10,000	114	126	19.4	21.5	12.5	15.0
12,000	107	119	18.2	20.3	11.5	13.9
14,000	102	114	17.4	19.4	10.8	13.1

Gasoline = 5.87 lbs per gallon @ 70° F.

Altitude Leaning Schedule
IO-550-D, -E, -F, -L
Full Rich, 2700 RPM

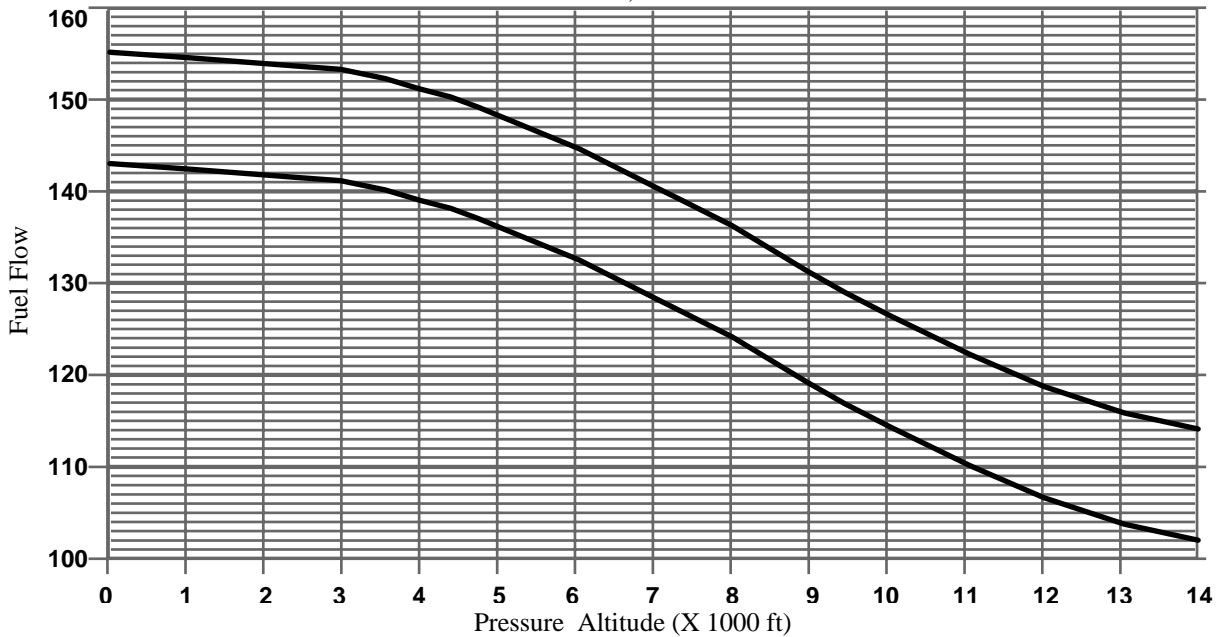

CHART 9

ISSUED			REVISED			 Teledyne Continental Motors, Inc. <small>A Teledyne Technologies Company</small> P.O. Box 90 Mobile Alabama • 251-438-3411	PAGE NO	REVISION
MO	DAY	YEAR	MO	DAY	YEAR		30 of 38 SID97-3	E
03	24	1997	06	17	2008			

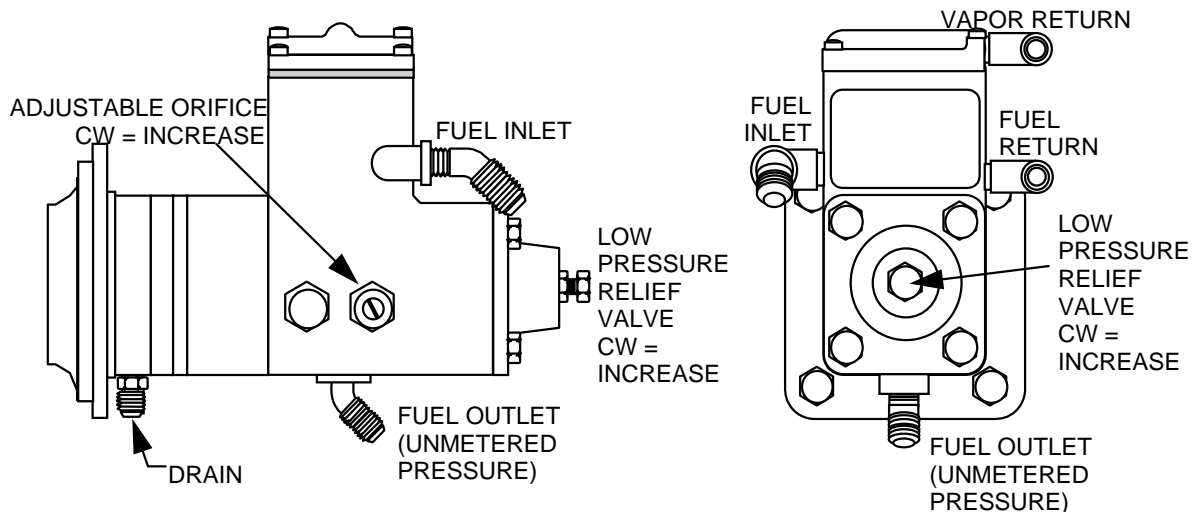

FIGURE 1 - NATURALLY ASPIRATED ENGINE FUEL PUMP

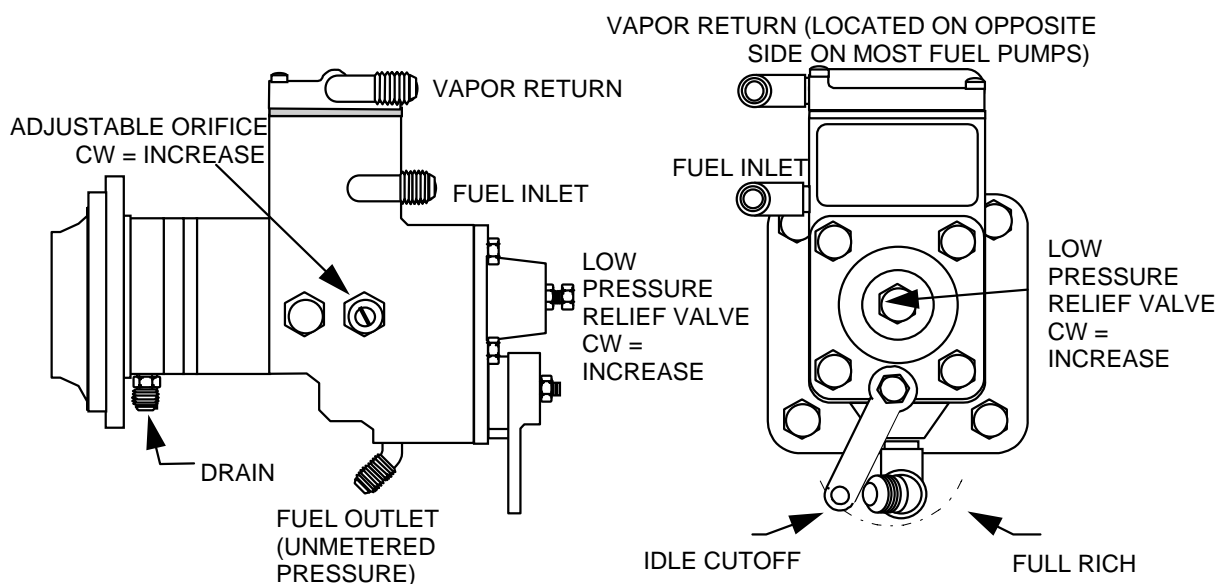

FIGURE 2 - NATURALLY ASPIRATED ENGINE (MIXTURE CONTROL EQUIPPED) FUEL PUMP

ISSUED			REVISED			PAGE NO	REVISION
MO	DAY	YEAR	MO	DAY	YEAR		
03	24	1997	06	17	2008	31 of 38 SID97-3	E

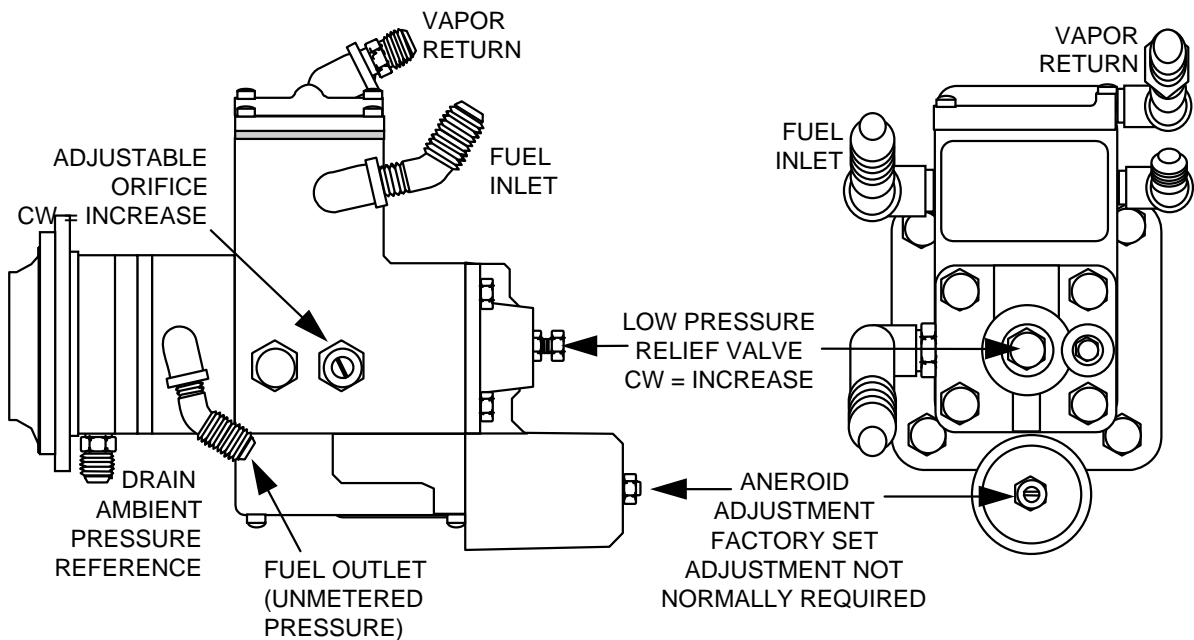
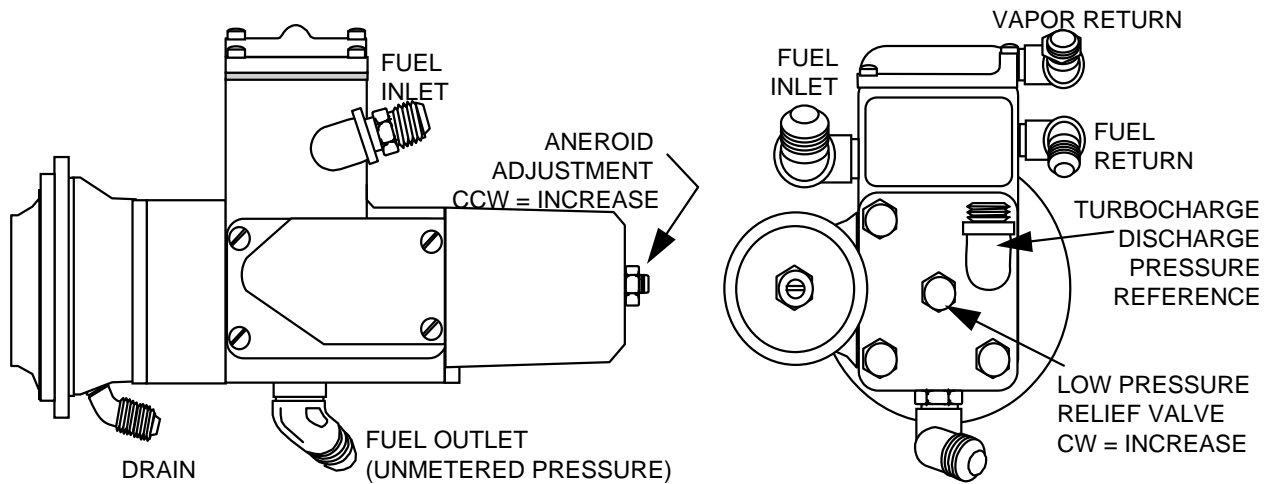

FIGURE 3 - ALTITUDE COMPENSATING FUEL PUMP



**FIGURE 4 - ANEROID EQUIPPED FUEL PUMP
TURBOCHARGED ENGINE**

ISSUED			REVISED			PAGE NO	REVISION
MO	DAY	YEAR	MO	DAY	YEAR		
03	24	1997	06	17	2008	32 of 38 SID97-3	E

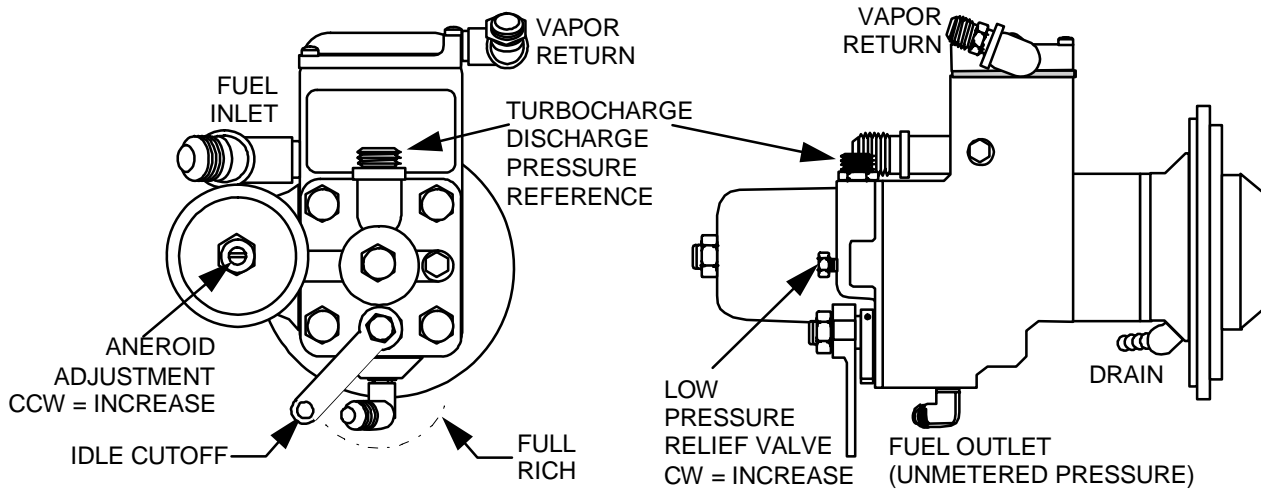

FIGURE 5 - ANEROID & MIXTURE CONTROL EQUIPPED FUEL PUMP TURBOCHARGED ENGINE

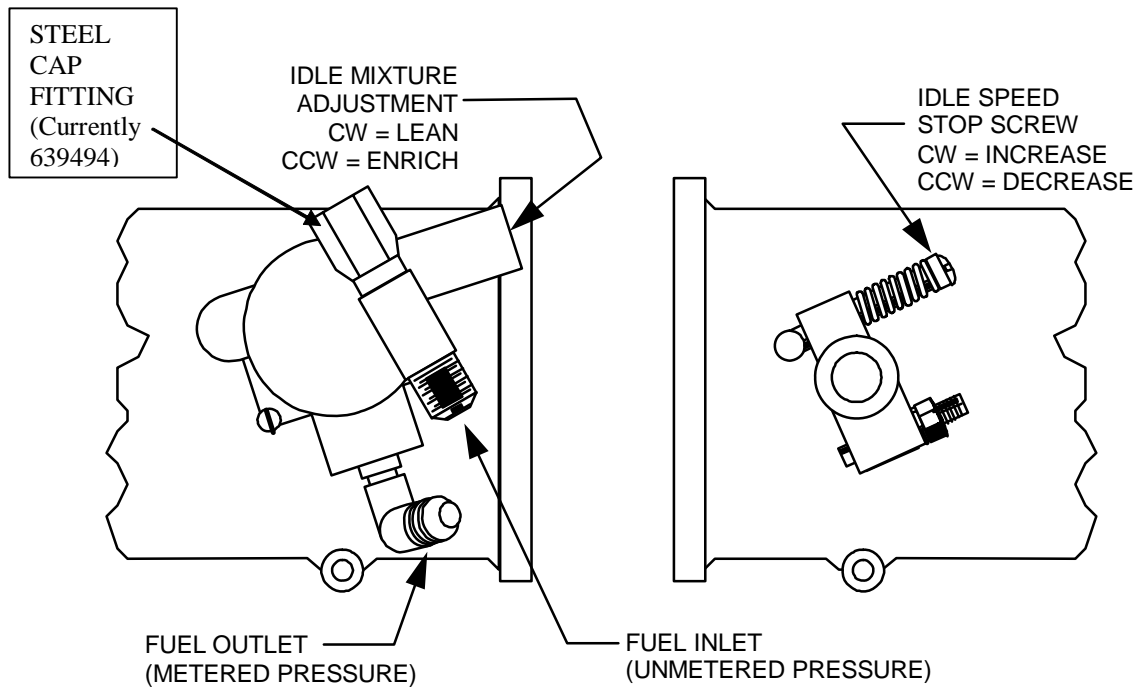

FIGURE 6 - THROTTLE & METERING ASSEMBLY

ISSUED			REVISED			PAGE NO	REVISION
MO	DAY	YEAR	MO	DAY	YEAR		
03	24	1997	06	17	2008	33 of 38 SID97-3	E

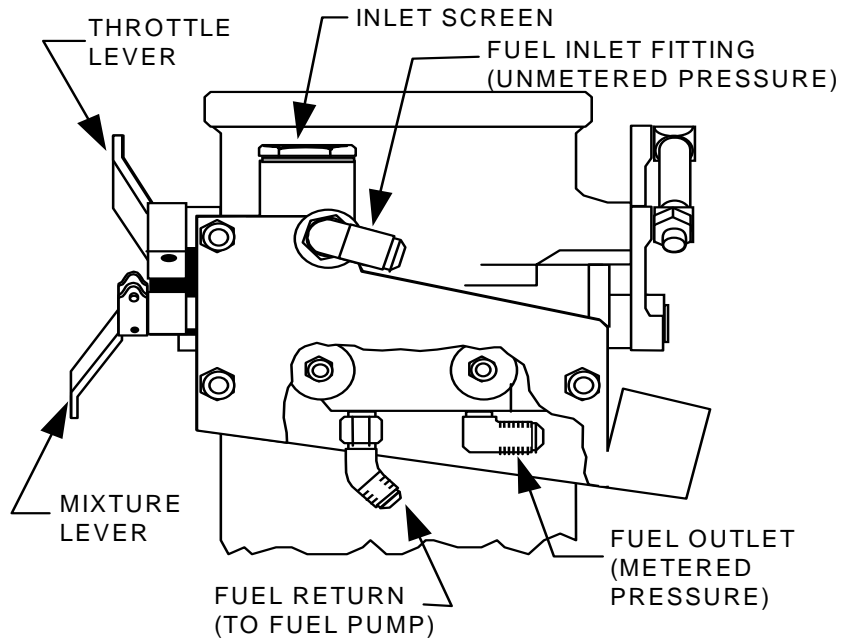

FIGURE 7 - THROTTLE & CONTROL ASSEMBLY - FRONT VIEW (EXCEPT GTSIO-520-D,F,H,K,L,M,N)

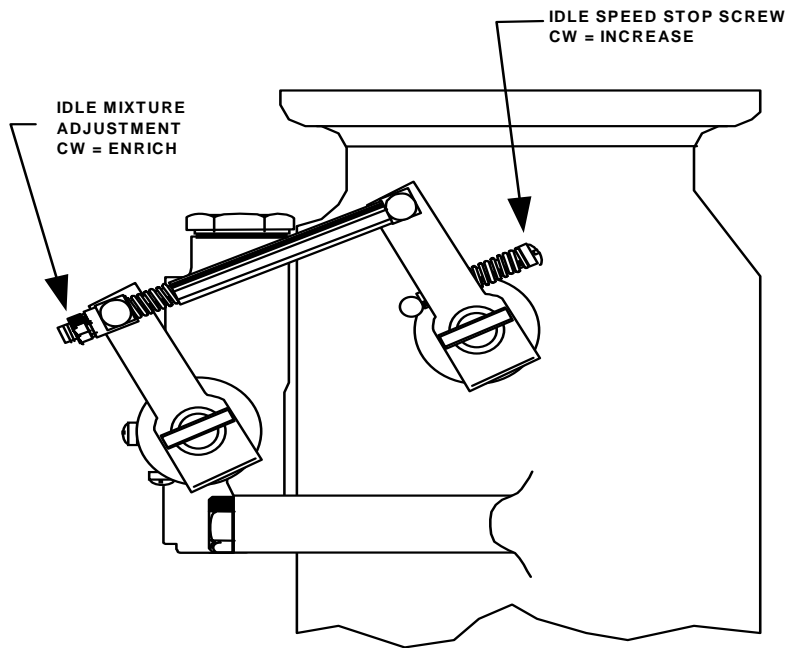
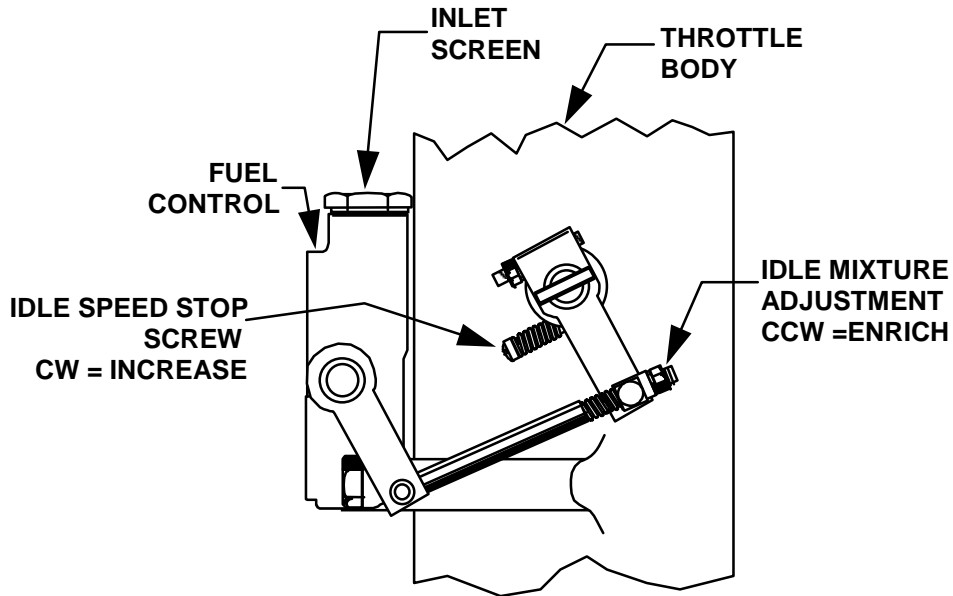
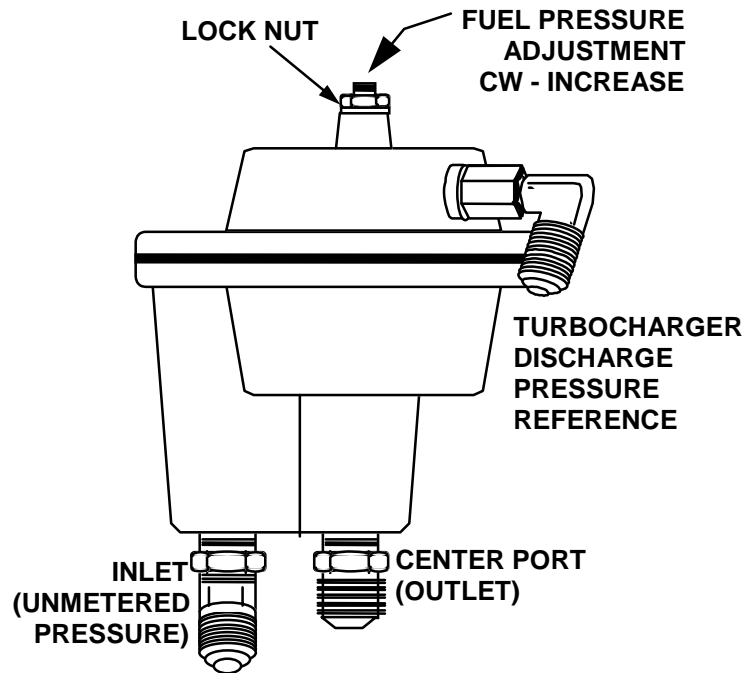

FIGURE 8 - THROTTLE & CONTROL ASSEMBLY SIDE VIEW (EXCEPT GTSIO-520-D, F, H,, K, L, M, N)

ISSUED			REVISED			PAGE NO	REVISION
MO	DAY	YEAR	MO	DAY	YEAR		
03	24	1997	06	17	2008	34 of 38 SID97-3	E



**FIGURE 9 - THROTTLE & CONTROL ASSEMBLY
(ALL GTSIO-520 EXCEPT GTSIO-520-C, F & K)**



**FIGURE 10 - FUEL PRESSURE REGULATOR
FOR TURBOCHARGED ENGINES**

ISSUED			REVISED			PAGE NO	REVISION
MO	DAY	YEAR	MO	DAY	YEAR		
03	24	1997	06	17	2008	35 of 38 SID97-3	E

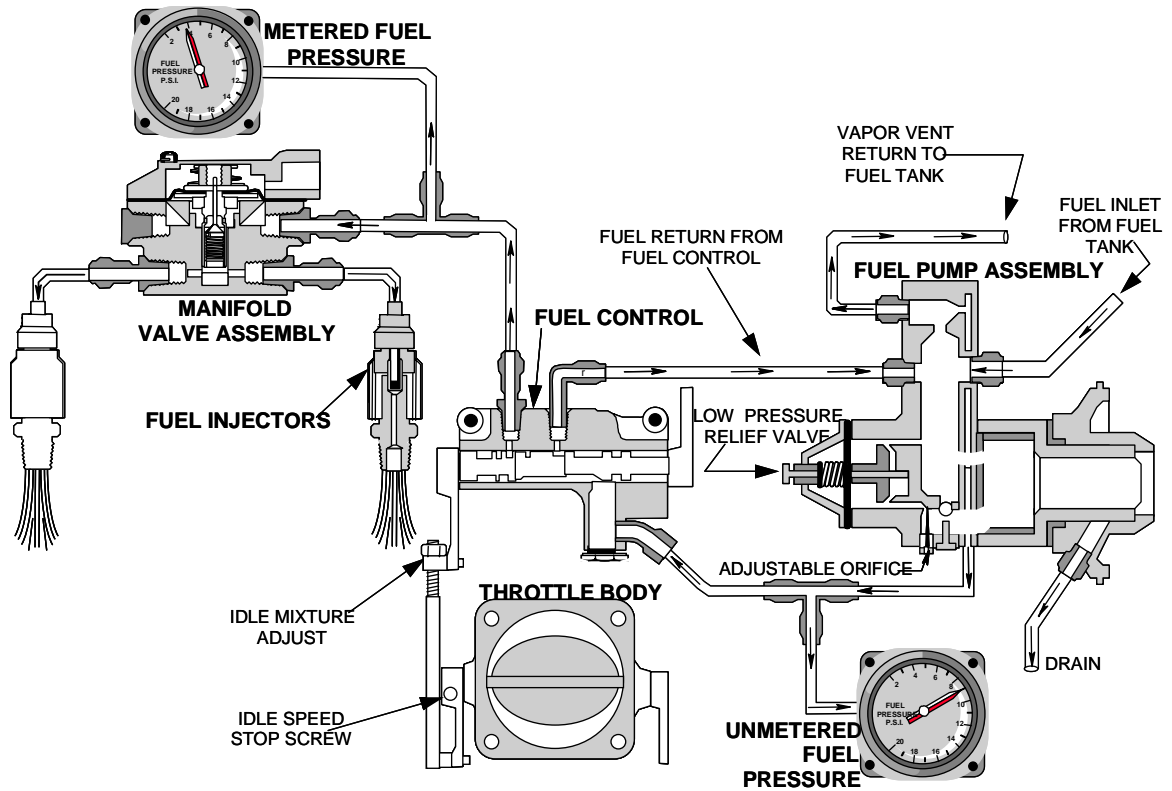

FIGURE 11-Typical Naturally Aspirated Fuel System Schematic

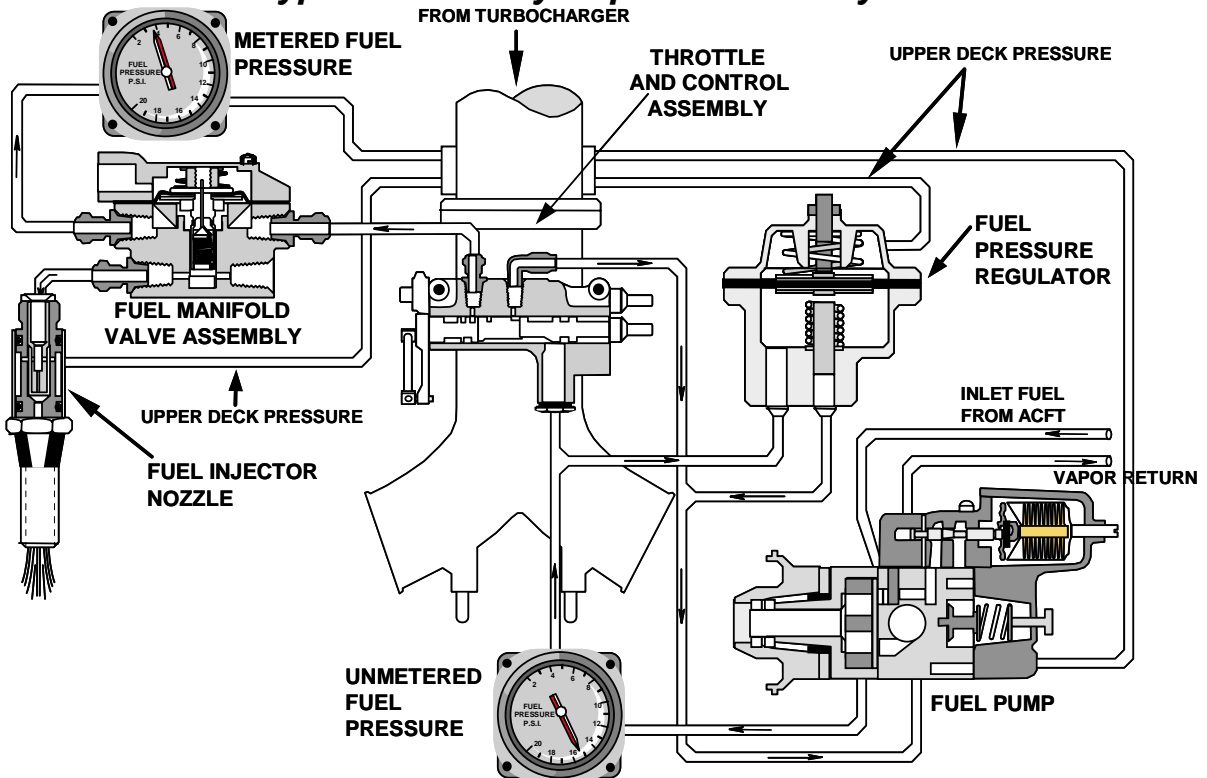

FIGURE 12-Typical Turbo-Charged Fuel System Schematic (With Regulator)

ISSUED			REVISED			PAGE NO	REVISION
MO	DAY	YEAR	MO	DAY	YEAR		
03	24	1997	06	17	2008	36 of 38 SID97-3	E

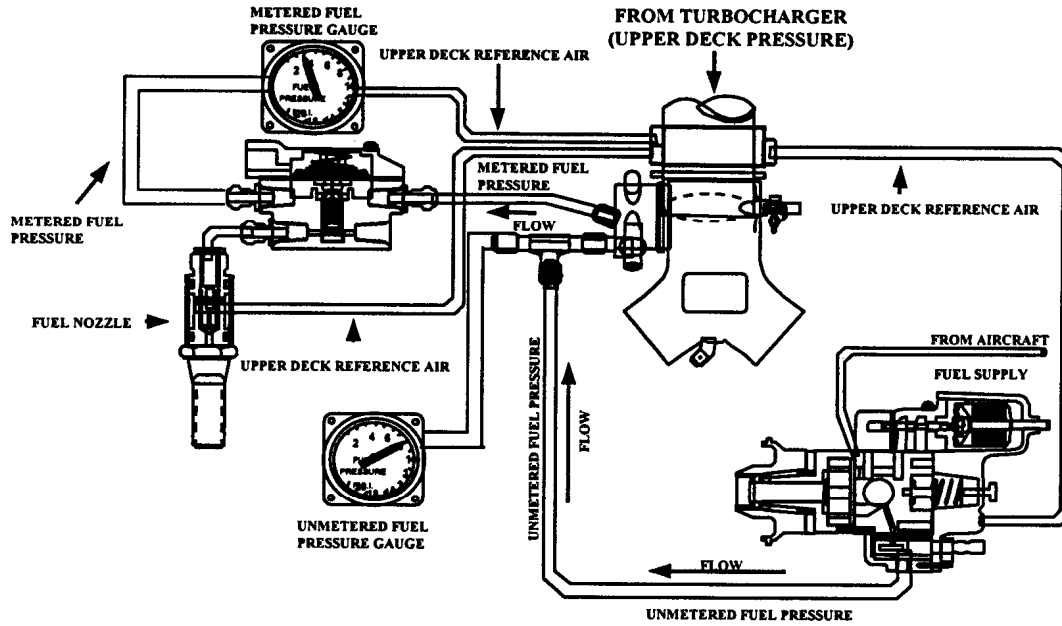

FIGURE 13
 TURBOCHARGED ENGINE FUEL SYSTEMS
 WITH FUEL PUMP HAVING INTEGRAL MIXTURE CONTROL

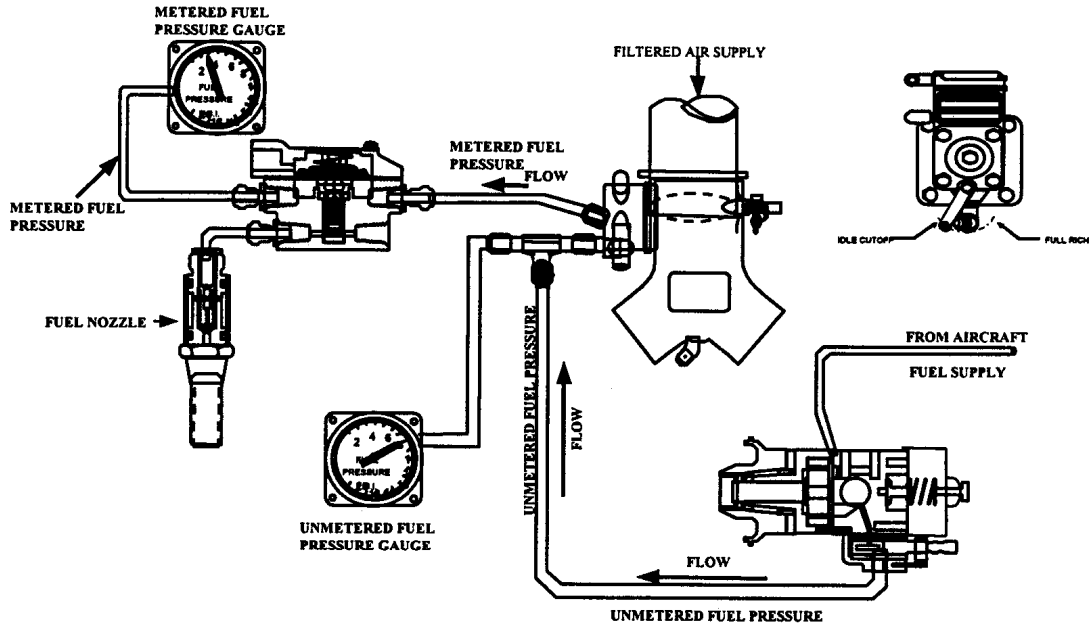

FIGURE 14
 Naturally Aspirated Engine Fuel System
 With Fuel Pump Having Integral Mixture Control

ISSUED			REVISED			PAGE NO	REVISION
MO	DAY	YEAR	MO	DAY	YEAR		
03	24	1997	06	17	2008	37 of 38 SID97-3	E

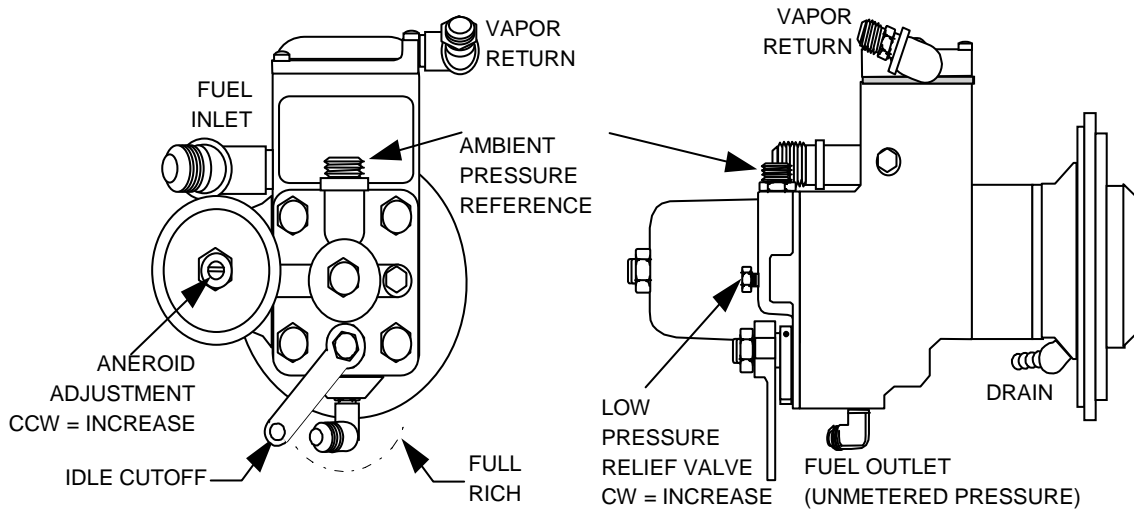

FIGURE 15 - ANEROID & MIXTURE CONTROL EQUIPPED FUEL PUMP

ISSUED			REVISED			PAGE NO	REVISION
MO	DAY	YEAR	MO	DAY	YEAR		
03	24	1997	06	17	2008	38 of 38 SID97-3	E

